

Assembly Instructions

Please keep for future reference

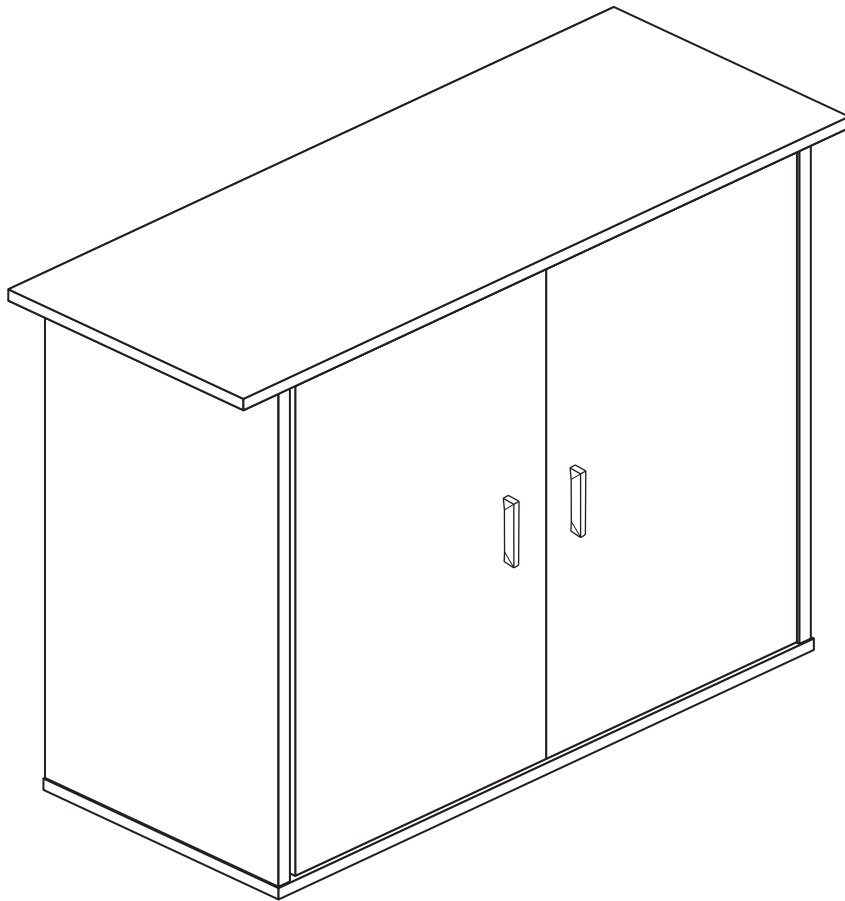

Aqua LED 100



Version 1 : 05/12/2014

Important - Please read these instructions fully before starting assembly

ALR3124

Safety and Care Advice

Important - Please read these instructions fully before starting assembly

- Warning: This unit weighs approximately 18kgs. Please lift with care.
- Check you have all the components and tools listed.
- Remove all fittings from the plastic bags and separate them into their groups.
- Keep children and animals away from the work area, small parts could choke if swallowed.
- Parts of the assembly will be easier with 2 people.
- Make sure you have enough space to layout the parts before starting.
- Assemble the item as close to its final position (in the same room) as possible.
- Assemble on a soft level surface to avoid damaging the unit or your floor (use opened out unit carton).
- We do not recommend the use of power drill/drivers for inserting screws, as this could damage the unit. Only use hand screwdrivers.
- Safety note: If there is any chance of this unit being pulled over by children etc. it is recommended that the unit is secured to a wall using suitable fixings (not supplied).
- Dispose of all packaging carefully and responsibly.



Care and maintenance

- Only clean using a damp cloth and mild detergent, do not use bleach or abrasive cleaners.
- From time to time check that there are no loose screws on this unit.
- This product should not be discarded with household waste. Take to your local authority waste disposal centre.

Contact Us

Aqua Pacific UK Ltd.
Unit 10, Oriana Way
Nursling Industrial Estate
Southampton
SO16 0YU

Tel +44 (0) 2380 734000
Fax +44 (0) 2380 740200
Sales@aquapacific.co.uk

Panels & Fittings

Please check you have all the panels and fittings listed below

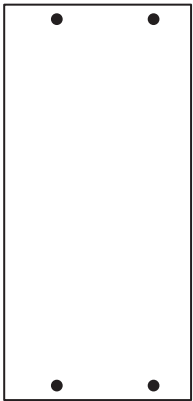

1 Side (D3040A)
(654 x 309mm) x 2



2 Back (D3045A)
(654 x 260mm) x 2

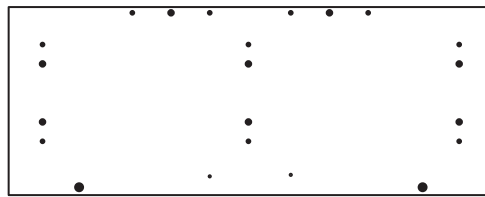

3 Top (D3043A)
(801 x 311mm)

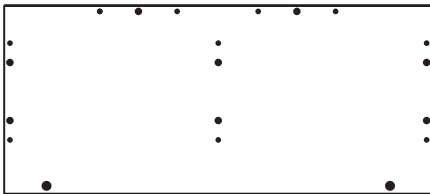

4 Base (D3044A)
(708 x 311mm)

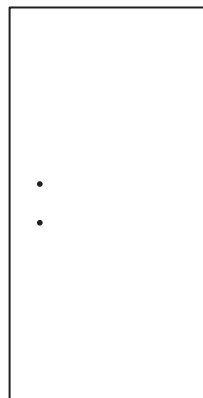

5 Door (D3047A)
(648 x 332mm)

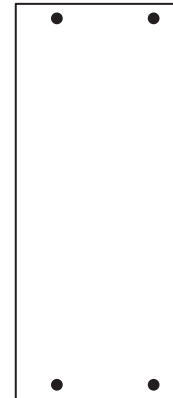

6 Divider (D3046A)
(654 x 273mm)



Wooden Dowel (F22) x 16

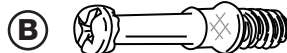

Large Metal Dowel (F901) x 20



Large Locking Nut (F900) x 20

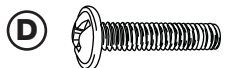

19mm Screw (F461) x 4



13mm Screw (F109) x 6



Plastic Nail (F91) x 4



Sprung Pivot (F580) x 4



Pivot Washer (F581) x 4



Handle (F955)

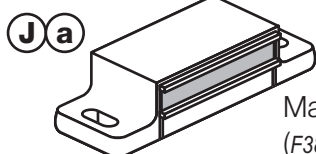

Magnetic Catch (F38) x 2

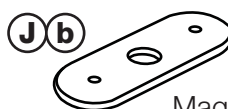

Magnetic Plate (F41) x 2

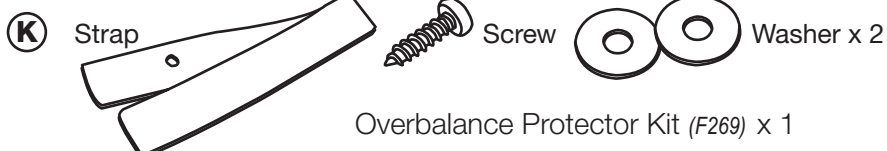

Overbalance Protector Kit (F269) x 1

Step 1

Prepare the 2 Sides

Tap 4 Wooden Dowels into each of the Sides.

Insert 4 Large Locking Nuts into each of the Sides.

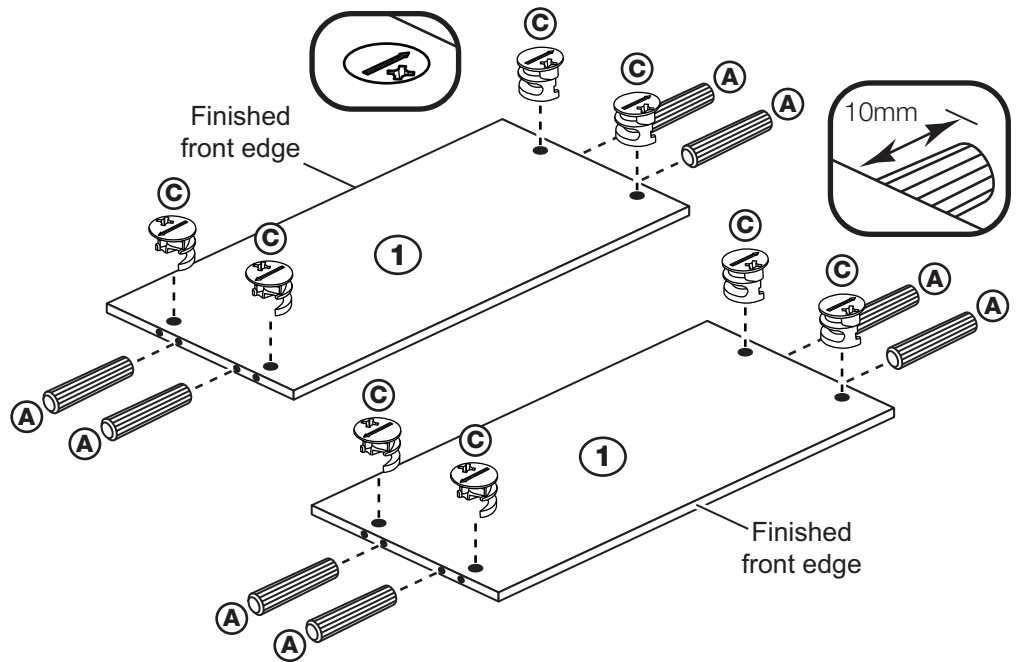

Step 2

Prepare the Divider

Tap 4 Wooden Dowels into the Divider.

Insert 4 Large Locking Nuts into the Divider.

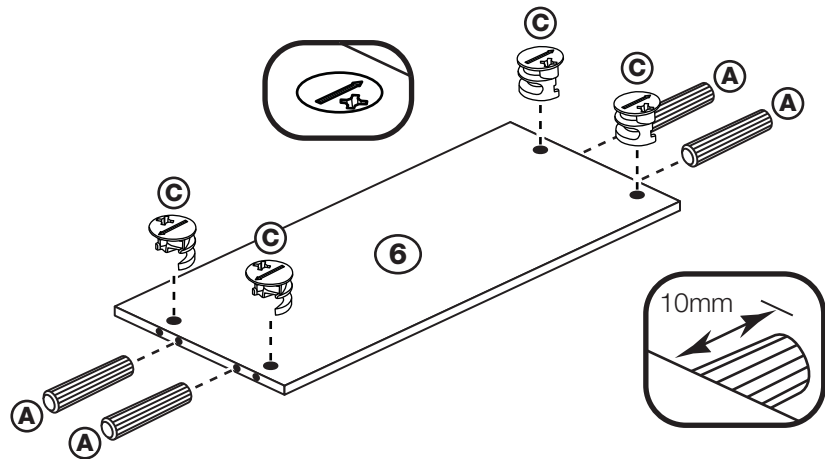

Step 3

Prepare the Top

Screw 10 Metal Dowels into the Top.

Push 2 Pivot Washers into the Top.

Fit 2 Magnetic Catches to the Top using the 13mm Screws. Ensure you fit the Magnetic Catches as shown.

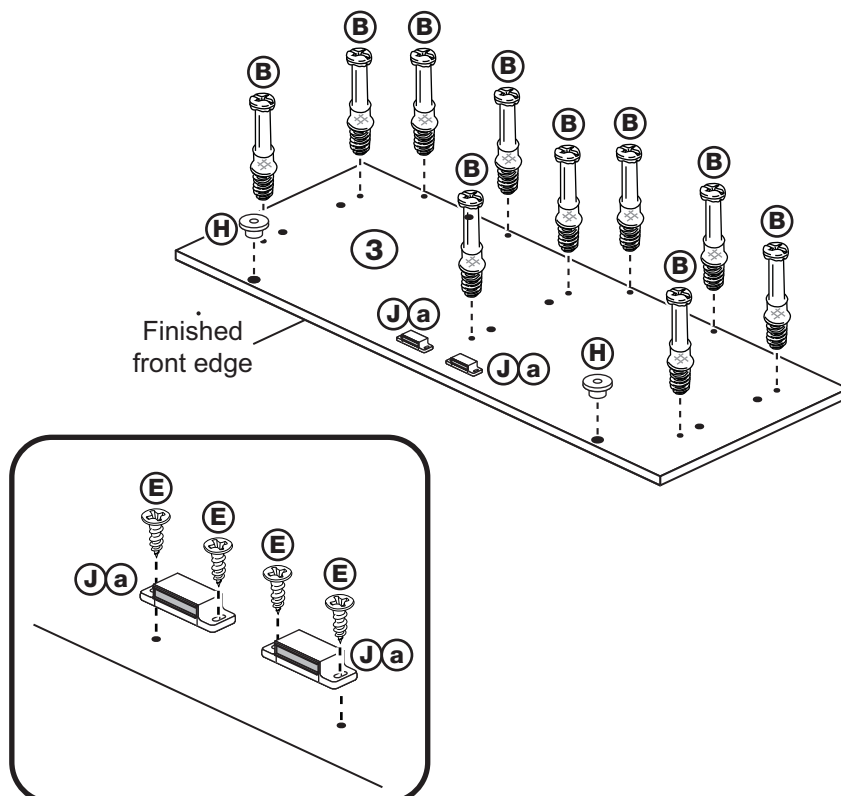

Step 4

Fit a Side to the Top

Push a Side down onto the Top.

Use a screwdriver to tighten the 2 Large Locking Nuts fitted to the Side.

Note: Turn the large locking nuts as far as they will go - more than 1/2 a turn.

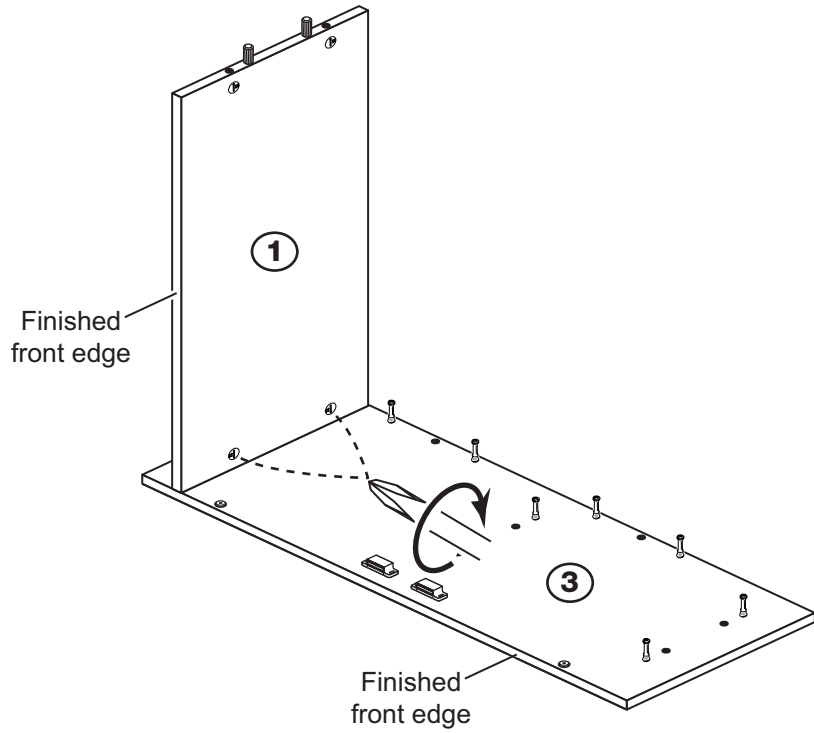

Step 5

Prepare the Backs

Tap 2 Wooden Dowels into each of the Backs.

Insert 4 Large Locking Nuts into each of the Backs.

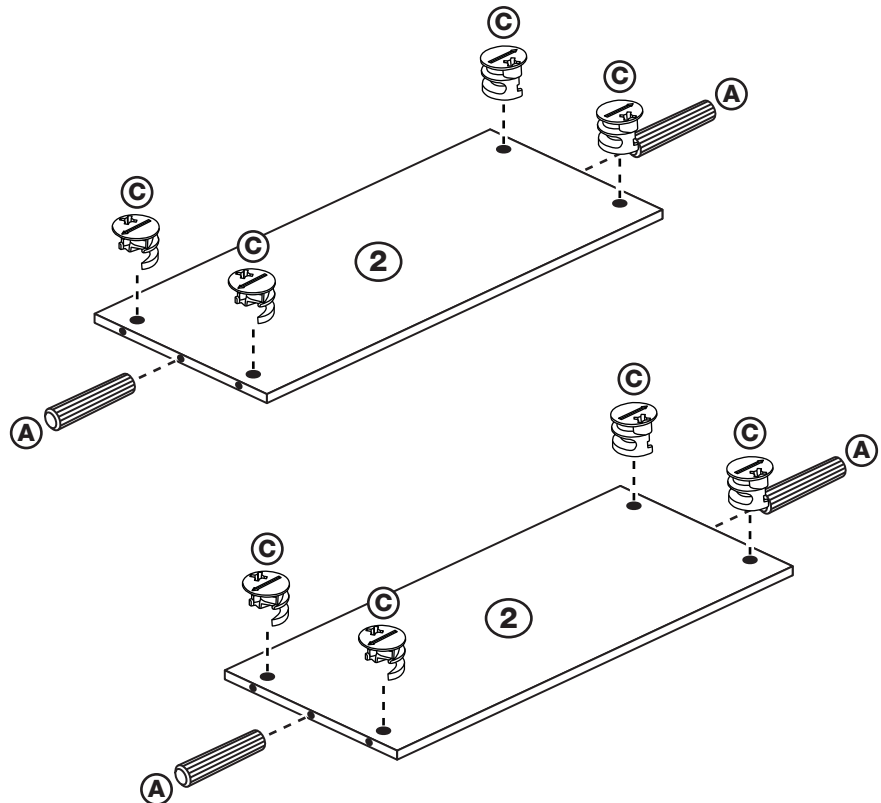

Step 6

Fit the Backs

Push the Backs down onto the Top.

Use a screwdriver to tighten the 4 Large Locking Nuts fitted to the Backs.

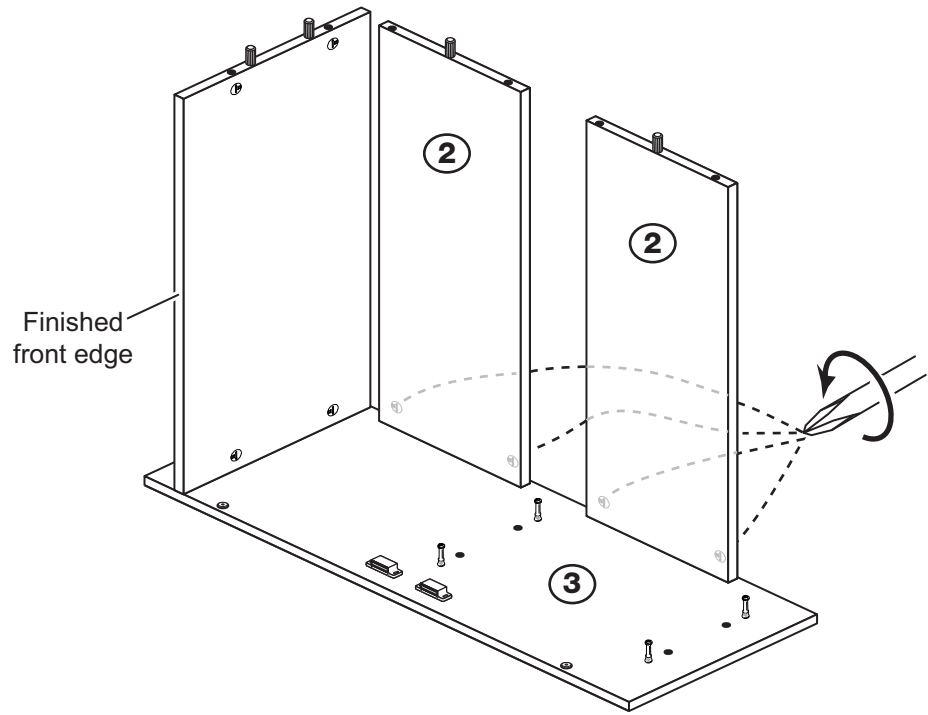

Step 7

Fit the Divider and the other Side

Push the Divider down onto the Top.

Use a screwdriver to tighten the 2 Large Locking Nuts fitted to the Divider.

Push the Side down onto the Top.

Use a screwdriver to tighten the 2 Large Locking Nuts fitted to the Side.

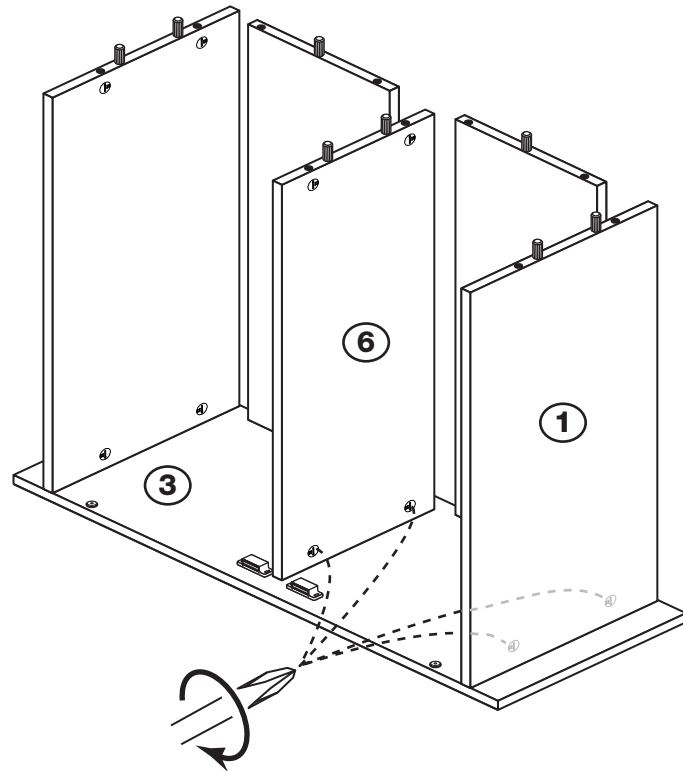

Step 8

Prepare the Base

Screw 10 Metal Dowels into the Base

Push 2 Pivot Washers into the Base.

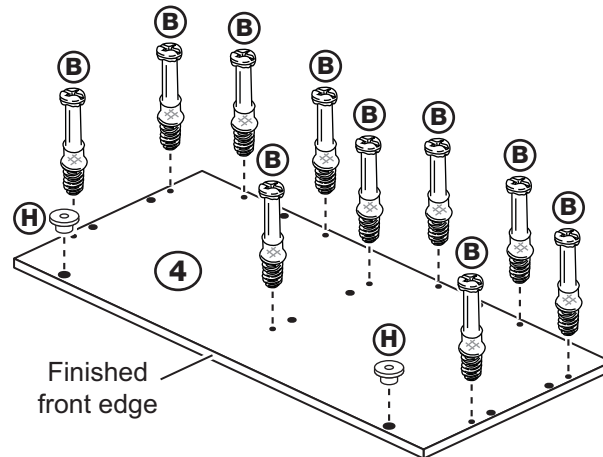

Step 9

Fit the Base

Push the Base down onto the Sides, Divider, and Backs.

Use a screwdriver to tighten the 10 Large Locking Nuts fitted to the Sides, Divider, and Backs.

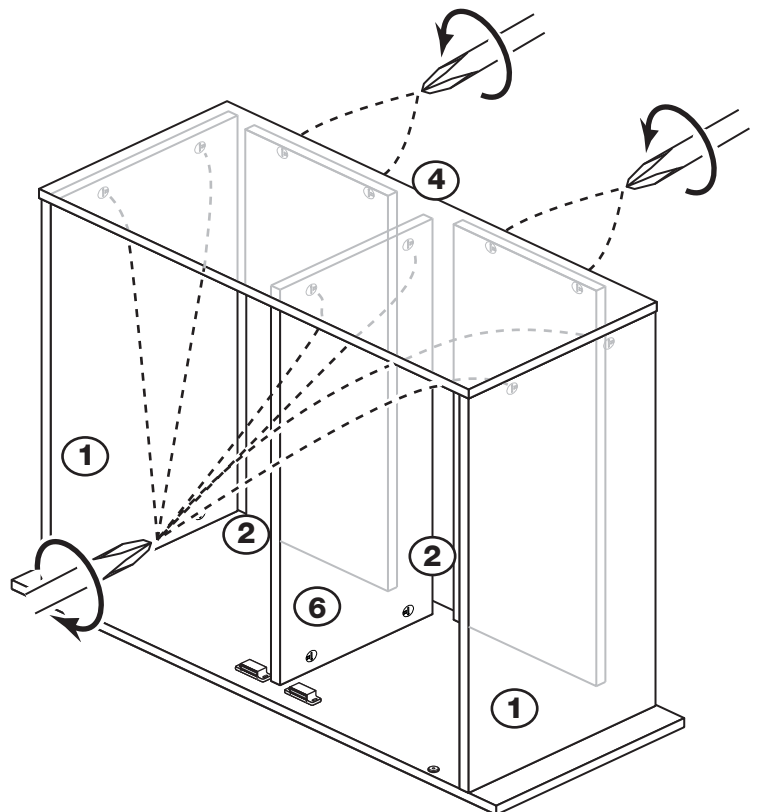

Step 10

Fit the 4 Plastic Nails

Tap 4 plastic nails into each corner of the Base about 10mm from the edges.

Stand the unit up

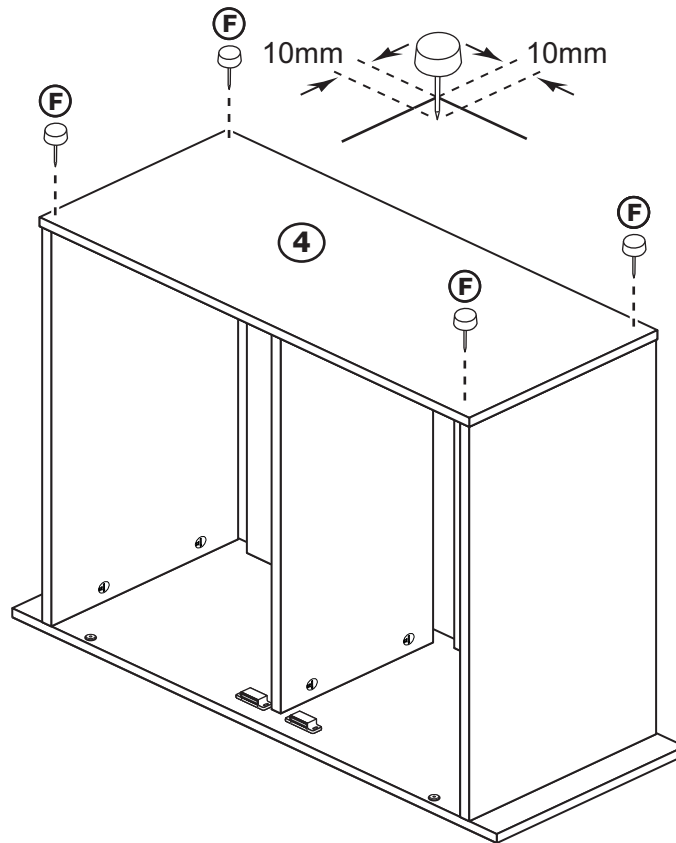

Step 11

Prepare the doors

Push 2 Sprung Pivots into each Door.

Screw a Magnetic Plate onto each Door using a 13mm Screw.

IMPORTANT!

You will need to fit the plates as shown to create a pair of doors.

Fit each plate using the dimension shown and close to the top of the door.

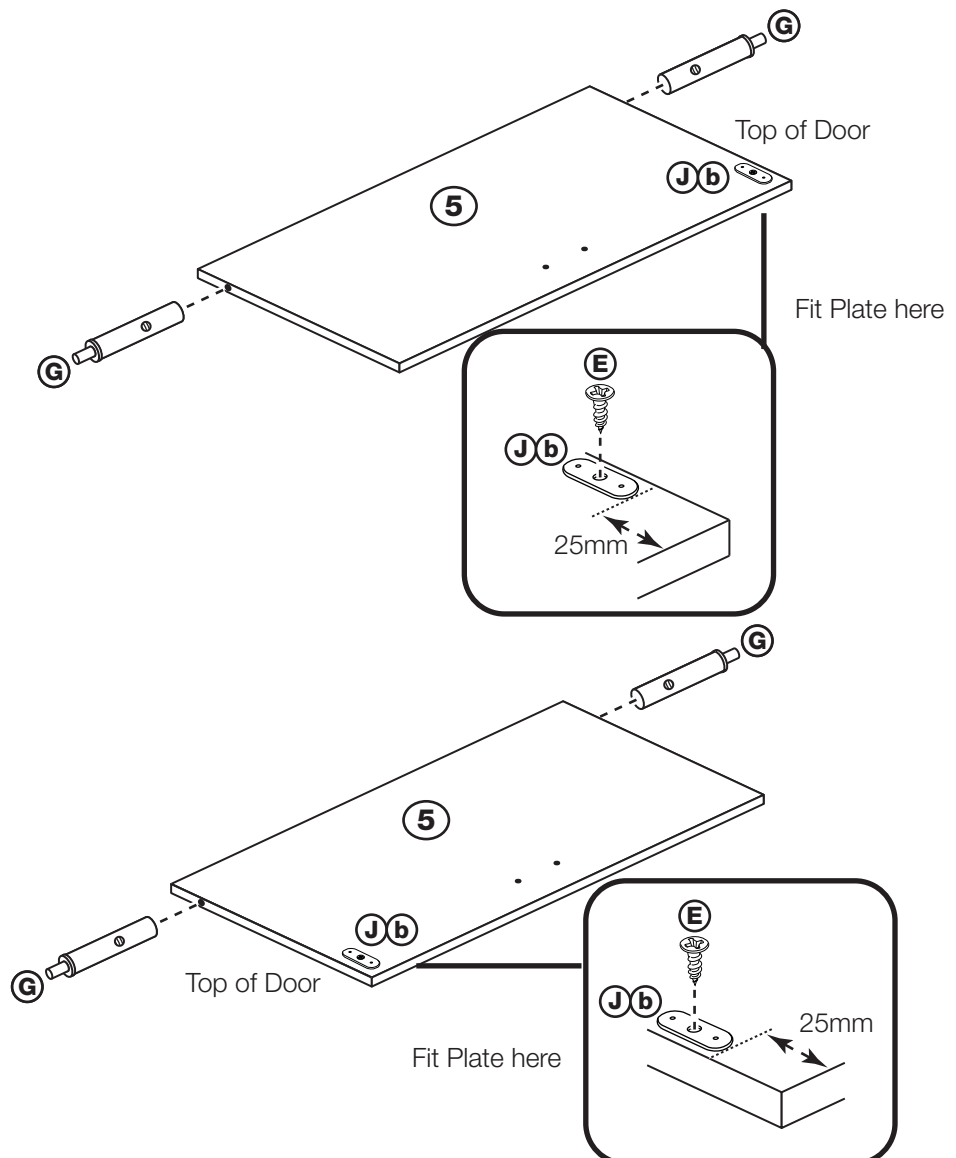

Step 12

Fit the Doors

Locate the Sprung Pivot at the bottom of the Door into the Pivot Washer on the Base.

Press down the metal lug in the Sprung Pivot at the top of the Door and locate it into the Pivot Washer in the Top.

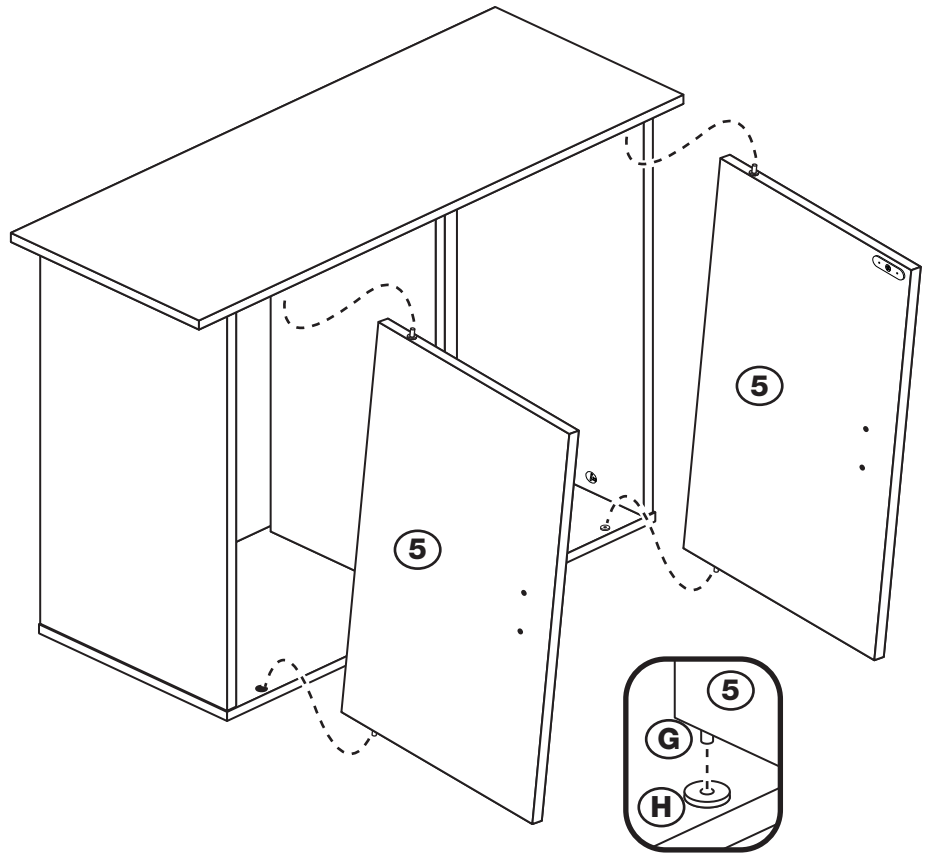

Step 13

Fit the handles

Attach the 2 Handles to the Doors using 4 19mm Screws.

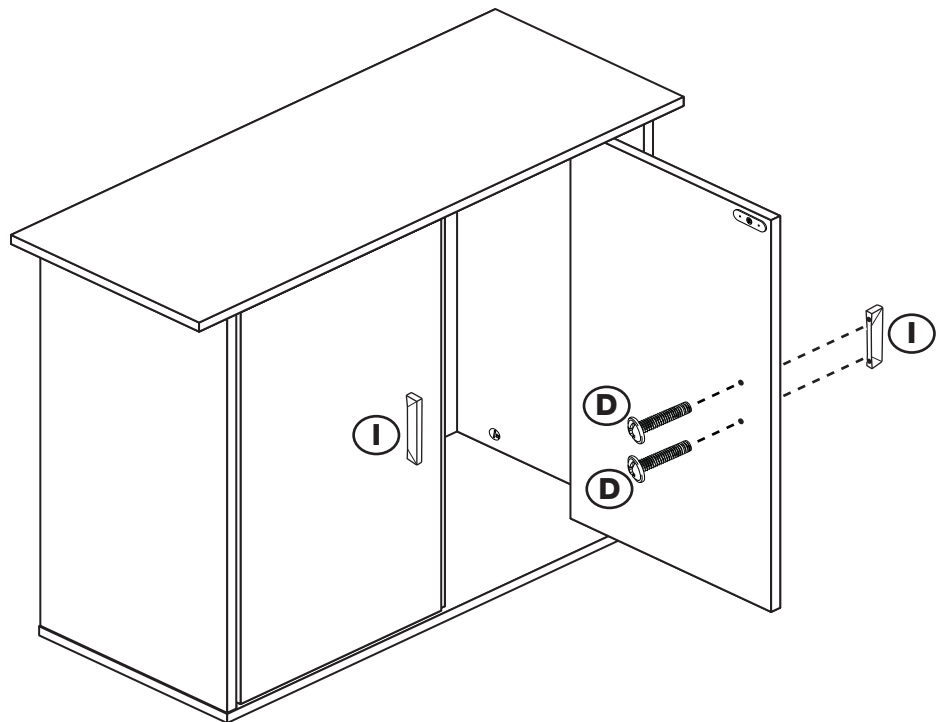

Step 14

Fit the overbalance protector

To prevent possible overbalancing we recommend that this unit is secured to a suitable wall by fitting of the overbalance protector kit to the unit, or an alternative fixing method of your choice.

Wall fixings are not supplied as they will need to suit the wall type.

Note: Take care when drilling the wall that you do not drill into any pipes, wires etc. If in doubt, consult an expert.

Example

