

NanoReef

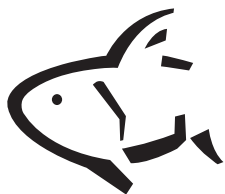

Aqua One®

Inspiring Excellence in Fish Care!

35

1+1
YEAR
GUARANTEE

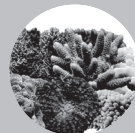

Instruction version: 22/07/2015

www.aquaone.com.au

Important Safeguards

To guard against injury, basic safety precautions should be observed, including the following:

1. Read and follow all safety instructions and important notices in these instructions as well as on the product itself.

2. This appliance is not intended for use by children or infirm persons without supervision. Young children should be supervised to ensure that they do not play with the appliance.

3. To avoid possible electric shocks, special care should be taken since water is employed in the use of aquarium equipment. For each of the following situations do not attempt repairs yourself. Return the appliance to an authorised service facility for service or discard the appliance.

a. If the appliance or any electrical component of the appliance (non-immersible equipment only) falls into the water or gets wet, do not reach for it. Unplug it and then retrieve it.

b. If the appliance shows any sign of abnormal water leakage, immediately unplug it from the power source.

c. Carefully examine the appliance after installation. It should not be plugged in if there is water on parts which are not intended to be wet.

d. Do not operate the appliance if it has a damaged cord or plug, or if it is malfunctioning, or dropped or damaged in any manner.

4. A “drip loop” (see graphic) should be arranged for each cable connecting an aquarium to a power supply. The drip loop is the part of the cable below the level of the power supply. It prevents water travelling down the cable and coming into contact with the power supply. If the plug or the socket does get wet, do not unplug the appliance. Disconnect the fuse or circuit breaker that supplies the power to the appliance, then unplug and examine for presence of water in the socket.

5. Always unplug the appliance from the electrical outlet when not in use, before putting on or taking off parts, before any type of maintenance or cleaning.

6. Never yank the cable to pull it from the socket. Pull the plug carefully to disconnect.

7. Do not use the appliance for reasons other than the intended use. The use of attachments that are not recommended or sold by the manufacturer may cause the product to be unsafe. This is not recommended.

8. Do not install or store the appliance where it will be exposed to weather or temperatures below freezing.

9. Make sure any component mounted on a tank is securely installed before operating it.

10. Ensure input voltage is the same voltage as your local power supply.

11. If an extension cable is used it should have the proper rating. Care should be taken to arrange the cord so that it will not be tripped or pulled.

12. A G.F.C.I (Ground fault circuit interrupter) & surge protector is recommended for all electrical appliances.

13. Ensure your hands are dry when turning the power switch on/off and when inserting/removing the power cable from the socket.

14. If you are in any doubt about the electrical installation or safety of this product you must consult a qualified electrician.

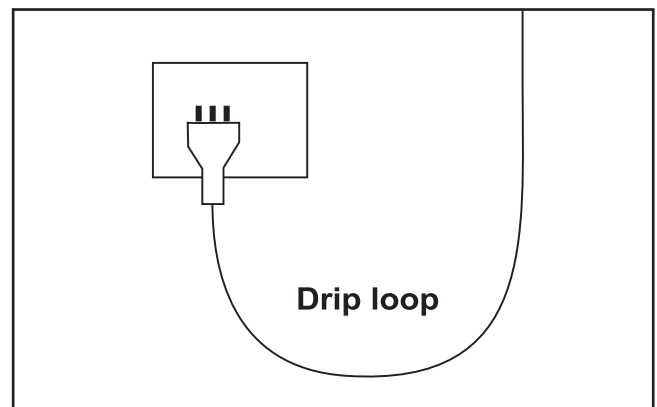

For Guarantee Conditions, please refer to the Guarantee form that is enclosed with this product.

All products are supplied with fitted plugs. This plug should not be tampered with in any way or removed. Removal or tampering with the plug invalidates our guarantee offered with this product.

For UK a 3 pin adaptor is supplied with the product and this must be used.

Before First Use / Preparation

Read and follow all the instructions, even if you feel you are familiar with the product and find a place to keep the instructions handy for future reference. Your attention is drawn particularly to the sections concerning **“IMPORTANT SAFEGUARDS”** and the **“GUARANTEE CONDITIONS”**. Please ensure you retain your original purchase receipt in the event that guarantee service is required.

Carefully unpack the aquarium making sure you keep all the packing material until all the parts of the product have been found and the product has been assembled.

This product is shipped to you in a factory sealed carton. Should the product malfunction in any way or if the unit is damaged and requires replacement, contact the retailer where the product was purchased for inspection.

Replacement Parts & Filter Media

Use Aqua One Genuine Spare Parts Only. See your local Aqua One Dealer and refer to the spare part numbers listed in the instructions supplied with the accessories. Alternatively you will find these numbers on the silver label located on electrical items.

NanoReef 35 Sponge 159S

Know Your Aquarium

NanoReef 35

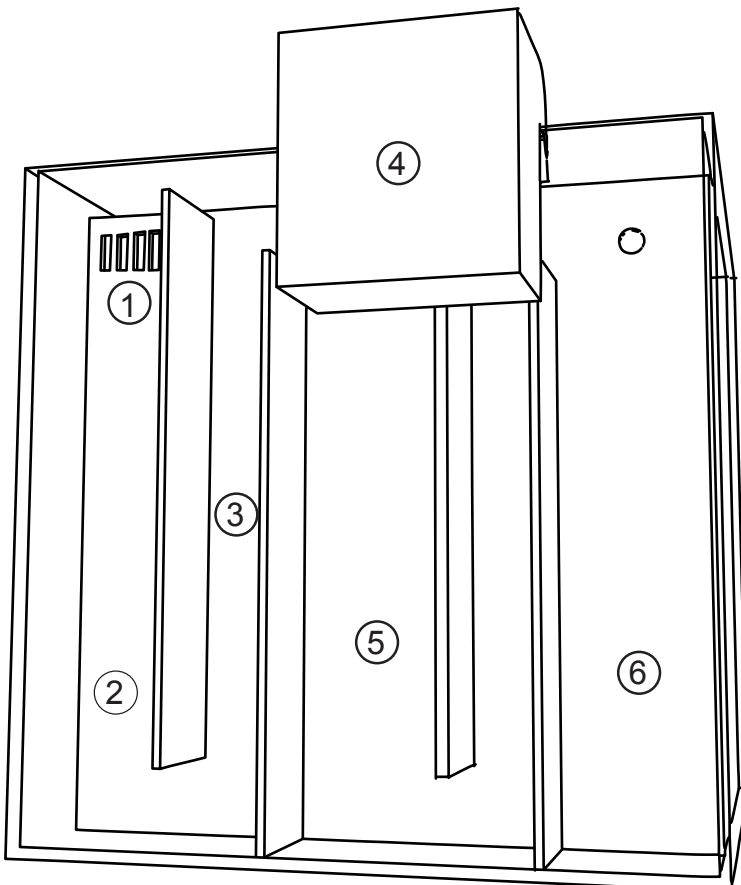

Set up/Parts

1. Inlet
2. Sponge
3. Heater
4. Protein Skimmer
5. Sintered Glass Substrate
6. Return Pump

Set Up Instructions

Refer to previous page for location of filter components.

1. Consider where you are going to place the aquarium. Keep it away from direct light or areas with large temperature fluctuations.

2. Place the aquarium on a flat level surface strong enough to support its weight (approx. 40kg). Aqua One aquarium cabinets are also available.

3. The filter unit comes preassembled with the exception of the heater, protein skimmer and pump. Rinse the filter media and place back in the filter.

4. Install the heater in the filter as shown on the previous page. Follow the instruction manual supplied with the heater to set the temperature. DO NOT turn the heater on when it is not submerged.

5. Remove the pump from its box and connect the outlet elbow. Attach the supplied hose to the outlet and attach the second elbow to the other end of the hose. Place the pump in the filter in the location shown in the diagram on page 3. Align the outlet elbow with the outlet hole in the front of the filter and push the duckbill outlet into the elbow. Ensure the pump is secured firmly using the suction cups on the rear of the pump.

6. Install the protein skimmer in the location shown on the previous page. Refer to the instruction manual supplied with the protein skimmer for installation and maintenance instructions.

7. Wash the substrate (gravel/sand) that will be used in the aquarium. In order to do this, place a portion of the substrate into a bucket and run water through it, churning with your hand. Continue until the water running out of the bucket is clear. Place the washed substrate into the aquarium.

8. It is now time to fill the aquarium with water. Fill the aquarium using prepared salt water or natural seawater so that the filter is filled to above the **minimum operating water level** mark.

9. Install the light unit as follows:

a. Slide the mounting brackets into the channels located at the bottom of the endcaps.

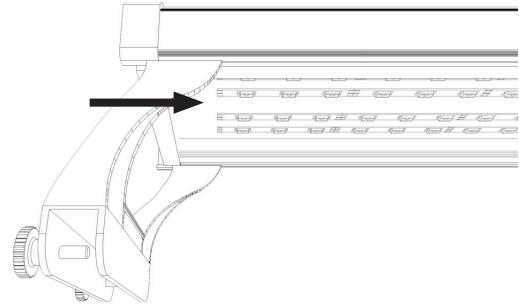

b. Mount the light unit on the side of the aquarium. Adjust the mounting brackets to the appropriate locations so that the brackets sit on the edges of the aquarium. Secure the light unit using the screws on the outside of the mounting brackets. Ensure the light unit is centred over the aquarium.

10. Ensure all power cables are dry and plug the light, heater and pump cables in at the power outlet. Switch the power on.

11. Place the glass lid on the top of the aquarium by:

a. Attach the lid brackets to the sides of the aquarium. Ensure they are spaced out sufficiently so that the lid is secure when placed on the brackets.

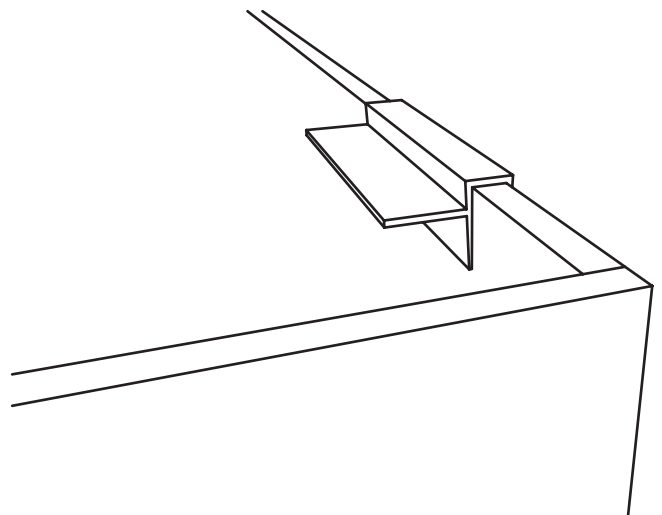

b. Place the lid on the brackets so that the feeding hole faces the front of the aquarium.

Maintenance

For maintenance instructions regarding the return pump, refer to the instruction booklet provided with the pump.

DAILY:

Feed your fish as per instructions on your fish food container.

Check temperature

Ensure all equipment is running correctly.

Ensure water level is safely above the **minimum operating water level** mark. When topping up evaporated water, always use dechlorinated tap water or suitably filtered water. When water evaporates from the aquarium, salt remains in the water so topping up with salt water will increase the salinity of the aquarium. Check salinity after topping up.

WEEKLY:

Test water parameters including pH, ammonia, nitrite, nitrate, phosphate, carbonate hardness and specific gravity (salinity). If you are keeping coral or other sensitive marine animals you may wish to perform further testing. Seek advice from your marine aquarium specialist.

Use quality test kits, Aqua One have a range of test kits (sold separately) which will allow you to easily and accurately monitor your water quality.

Some species require specific water conditions. Please seek advice from your marine aquarium specialist.

FORTNIGHTLY: 25% water change

What you will need: A bucket, gravel cleaner, towel, algae scraper, water conditioner and either synthetic salt or premixed/natural salt water. The fish and corals do not need to be removed while performing a water change.

1. Wash your hands.
2. Mix up your salt water according to the directions on the packaging of the salt mix. Or, have your premixed/natural salt water ready.
3. Check the pH, temperature and specific gravity of both the aquarium water and the new water. Make any adjustments that need to be made to the new water. You may want to purchase a second heater to warm the new water.
4. Once the water is ready to use, remove the light unit and glass lid and place them somewhere safe away from the water where they will not be broken or

damaged.

5. Turn the heater, protein skimmer and pump off.
6. Place a towel on the floor in front of the aquarium to guard from water spillage.
7. Use an algae scraper and gently remove any algae that is growing on the glass.
8. Using a gravel cleaner, remove 25% of the aquarium water. Take note of how much water is removed and be sure to have enough prepared water to replace all that is removed.
9. Remove the sponge from the filter and rinse it in water that has been removed from the aquarium.
10. Refill the aquarium using the prepared water so that the filter is filled to above the **minimum operating water level** mark.
11. Turn the heater and pump back on and ensure the water level is safely above the pump.
12. Allow the aquarium to run for 30 minutes then check the temperature, specific gravity and pH. Adjust if necessary.
13. Replace the glass lid and light unit.

Trouble Shooting

Specifications

BUBBLES ARE COMING OUT THE OUTLET INTO THE AQUARIUM

1. The water level in the filter is too low. Check specific gravity after topping up to the correct level.
2. The flow to the pump is restricted. Check the sponge and clean if necessary.

WATER FLOW INTO THE AQUARIUM HAS DROPPED

1. Pump needs to be cleaned. Refer to maintenance instruction provided with pump.
2. Outlet is blocked. Remove and clean the duckbill outlet.

Aquarium Model: NanoReef 35
Overall Dimensions (exc. light): 35 x 35 x 35cm
Aquarium Volume: 35L
Protein Skimmer: 240L/hr / 4.4W
Return Pump Flow Rate: 200L/hr
Light Wattage: 15W LED
Power Requirements: 220 ~ 240V
Suitable: Marine

Correct Disposal of this product



This marking indicates that this product should not be disposed with other household waste throughout the EU. To prevent harm to the environment or human health from uncontrolled waste disposal, recycle it responsibly to promote the sustainable reuse of material resources. To return your used device, please use the return and collection systems or contact the retailer where the product was purchased. They can take this product for environmental safe recycling.

Aqua One Manufacturers Guarantee 1 + 1 Year

The additional 1 Year **Extended Guarantee** applies when you REGISTER online with Aqua One. Register your Extended Guarantee at www.aquaone.com.au

The Aqua One Aquarium purchased must be installed upon a level surface and weight bearing cabinet and there upon level and load bearing flooring (using a level is recommended). The purchaser must consider the total weight of all items when installing an Aquarium which could be up to 1200kg dependant on the model and accessory items chosen. Consider this, 1L of water = 1kg weight.

About this Guarantee

The Manufacturer or Distributor, of Aqua One goods, is collectively known herein as "Aqua One". Please refer to contact details for Aqua One below or on the applicable Aqua One website. Any product that is covered by its own Guarantee (as enclosed with the product) is subject to the conditions of that Guarantee.

Australian Guarantee

Important note: This guarantee applies in addition to the guarantees, rights and remedies conferred by the Australian Consumer Law and other applicable Commonwealth, State and Territory legislation. The guarantee does not exclude, affect or limit those guarantees, rights or remedies, except to the extent that their application may lawfully be excluded or limited.

In particular, our goods come with guarantees that cannot be excluded under the Australian Consumer Law. You are entitled to a replacement or refund for a major failure and for compensation for any other reasonably foreseeable loss or damage. You are also entitled to have the goods repaired or replaced if the goods fail to be of acceptable quality and the failure does not amount to a major failure.

International Guarantee

The benefits given to the purchaser, under Guarantee, are in addition to all other statutory rights and remedies which the purchaser has in respect of goods under legislation in the applicable country of purchase. This Guarantee shall not affect any such rights and should be read subject to such legislation.

1.0. Terms and Conditions of Guarantee.

- 1.1. Aqua One warrants to the purchaser, for 1 Year from date of original purchase, to repair or replace goods where fault is found due to defective materials or faulty workmanship and where goods do not operate in accordance with the instructions.
- 1.2. All claims for repair or replacement must be made at place of purchase.
- 1.3. The original and dated Proof of Purchase (receipt) must be supplied with all goods claims. Please also provide this Guarantee where possible.
- 1.4. The Guarantee covers the Aquarium against gluing breakdown resulting in leakage.
- 1.5. All goods subject to claim under Guarantee should be prepared for transportation in the original packaging or other comparable packaging which offers the same degree of protection.
- 1.6. Where goods are repaired or replaced under Guarantee, these goods are Guaranteed for the remainder of either the original Guarantee or Extended Guarantee period.
- 1.7. Where claims on inspection reveal goods are in normal working order, Aqua One will request reimbursement of all reasonable costs incurred.

2.0. Other Terms and Conditions – Extended Guarantee

- 2.1. The Extended Guarantee period is for an additional 1 Year and commences on expiration of the standard guarantee period.
- 2.2. Application for Extended Guarantee is FREE of any registration cost to the purchaser on completion of the Extended Guarantee questionnaire which is found on the applicable Aqua One website (refer below).
- 2.3. Upon receipt and acceptance of the questionnaire, Aqua One will forward (by way of email) a Certificate of Extended Guarantee to the purchaser.
- 2.4. For more information on how we collect, hold, use and disclose personal information provided to us, please refer to our Privacy Statement on the Aqua One websites or write to our Privacy Officer, in your country of purchase.
- 2.5. Where Aqua One determines goods are being used in a manner contrary to the instructions, specifications or this Guarantee, Aqua One reserves the right to terminate Extended Guarantee for such goods and will provide written notice to the purchaser.

3.0. Exclusions and Limitations

Where permitted by local law, the following exclusions and limitations apply in regard to Guarantee:

- 3.1. Glass breakage, for whatever reason caused after Aquarium purchase.
- 3.2. Goods claims where fault is due to, but not limited by a) misuse b) neglect c) abuse d) fire or flood e) normal wear and tear f) accidental breakage g) Acts of God h) mains voltage fluctuation or supply problems i) connection to any voltage other than what is stated on the rating plate j) modification or tampering to electrical cord or plug, k) vermin, insects or foreign object l) liquid spillage or submersion of goods not designed to sustain such use or duress.
- 3.3. Where inspections reveal goods are in normal working order including where noise or vibration is consistent with normal goods operation.
- 3.4. Attempted repairs or modifications by unauthorised persons, including but not limited to the drilling of holes in the aquarium glass by unauthorised persons.
- 3.5. Where the goods factory rating plate has been removed, altered, damaged or is rendered illegible.
- 3.6. Where goods are not installed, operated or maintained in accordance with Aqua One's goods instructions, specifications or this Guarantee.
- 3.7. Replacement or repair of worn consumables or replacement of lost goods, parts or components.
- 3.8. Costs associated with goods transportation, removal, installation, postage or cost of insurance.
- 3.9. Any damage incurred whilst installing, transporting or moving the goods.
- 3.10. Subject to certain local statutory rights and obligations to the contrary, and this guarantee shall not affect those rights or obligations, where, to the full extent permitted by law: 1. all express and implied warranties and conditions under statute or general law, are expressly excluded and Aqua One, where permitted, will limit liability as follows and at Aqua One's option to: in regard to goods either a) the replacement of goods or supply of equivalent goods b) the repair of goods or the cost of replacing the goods or of acquiring equivalent goods OR in regard to services either c) the re-supply of services d) the cost to re-supply services.

4. The LED's used in this aquarium are designed to last up to 5 times longer than conventional light tubes. All LED's are made up of multiple LED diodes and occasionally individual LED's can breakdown as with all LED devices. The effectiveness of your LED will not reduce as much as a conventional light tubes output would over a period of 6 months. We would replace a unit subject to the terms of the warrantee if more than 20% of the individual LED's have failed.

4.1. Aqua One will not be liable for any loss or damage, including consequential loss or damage either directly or indirectly, or for any incidental expenses, of any kind, and in any way whatsoever.

(1) consumables include items such as filter media/cartridges, impellers and shafts, light tubes, lamps, bulbs and starters.

Aqua One may be contacted in:

Australia
Kong's (Aust.) Pty. Limited
PO Box 863, Ingleburn
1890 NSW Australia
www.aquaone.com.au

Hong Kong
Kong's Aquarium Supplies Co., Ltd
No 31, 3/F Thriving Industrial Centre
26-38 Sha Tsui Road, Tsuen Wan,
Hong Kong
www.aquaone.co.hk

New Zealand
Kong's (NZ) Limited
PO Box 15 - 183, Tauranga
3015 New Zealand
www.aquaone.co.nz

United Kingdom
Kong's (UK) Limited,
C/O Aqua Pacific UK Ltd.
PO Box 268
Romsey Hampshire, SO51 0WW
United Kingdom
www.aquaone.co.uk

This Aquarium is designed to help simplify general fish keeping. Please note, some specialist fish and aquatic animal or plant keeping require certain considerations, prior to purchase, to ensure proper and successful Aquarium keeping. Therefore, **Aqua One recommends, at time of Aquarium purchase, that you consult with your Aqua One Retailer in regard to the suitability of this product for the types of fishes, aquatic animals or plants you may wish to keep.** Special consideration should also be made in regard to filtration, aquarium heater and lighting requirements to ensure they are specific to your application.



Manufactured in China.
Designed in Australia by Aqua One.
*Aqua One and Aqua One Inspiring
Excellence in Fish Care!* are registered
trademarks or trademarks.

www.aquaone.com.au