





MiniReef 90 / 120





Read and follow all safety instructions and important notices in these instructions as well as on the product itself.



Before you work on your aquarium, wash your hands and arms. It is very important to remove dirt, moisturiser and other impurities.



Unpack all filter media and rinse before initial use. Rinse the inside of the aquarium with water to remove any dust or other contaminants.

Regular maintenance of this product and components are required in order to keep equipment within guarantee and to maintain fish health.



All fish have specific requirements for their care. Please seek advice from your Aqua One retailer for correct care requirements and species compatibility.

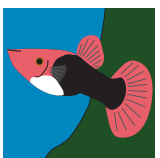

Like us on Facebook

Download the Aqua One App.
Available for iOS & Android





CUSTOMER CARE

Thank you for choosing this Aqua One product.

Your Aqua One product is covered for parts and labour for 1 year from the date of purchase as detailed in the terms of the Guarantee in this instruction manual. For any inquiries or concerns regarding this product or any of our products, please do not hesitate to contact your local Aqua One Retailer or visit Aqua One Customer Care online in your country of purchase via the websites listed.

Australia:
www.aquaone.com.au
New Zealand:
www.aquaone.co.nz
United Kingdom:
www.aquaone.co.uk
All other countries:
www.aquaone.com.au



Important Safeguards

To guard against injury, basic safety precautions should be observed, including the following:

1. Read and follow all safety instructions and important notices in these instructions as well as on the product itself.

2. This appliance is not intended for use by children or infirm persons without supervision. Young children should be supervised to ensure that they do not play with the appliance.

3. To avoid possible electric shocks, special care should be taken since water is employed in the use of aquarium equipment. For each of the following situations do not attempt repairs yourself. Return the appliance to an authorised service facility for service or discard the appliance.

a. If the appliance or any electrical component of the appliance (non-immersible equipment only) falls into the water or gets wet, do not reach for it. Unplug it and then retrieve it.

b. If the appliance shows any sign of abnormal water leakage, immediately unplug it from the power source.

c. Carefully examine the appliance after installation. It should not be plugged in if there is water on parts which are not intended to be wet.

d. Do not operate the appliance if it has a damaged cord or plug, or if it is malfunctioning, or dropped or damaged in any manner.

4. A “drip loop” (see graphic) should be arranged for each cable connecting an aquarium to a power supply. The drip loop is the part of the cable below the level of the power supply. It prevents water travelling down the cable and coming into contact with the power supply. If the plug or the socket does get wet, do not unplug the appliance. Disconnect the fuse or circuit breaker that supplies the power to the appliance, then unplug and examine for presence of water in the socket.

5. Always unplug the appliance from the electrical outlet when not in use, before putting on or taking off parts, before any type of maintenance or cleaning.

6. Never yank the cable to pull it from the socket. Pull the plug carefully to disconnect.

7. Do not use the appliance for reasons other than the intended use. The use of attachments that are not recommended or sold by the manufacturer may cause the product to be unsafe. This is not recommended.

8. Do not install or store the appliance where it will be exposed to weather or temperatures below freezing.

9. Make sure any component mounted on a tank is securely installed before operating it.

10. Ensure input voltage is the same voltage as your local power supply.

11. If an extension cable is used it should have the proper rating. Care should be taken to arrange the cord so that it will not be tripped or pulled.

12. A G.F.C.I (Ground fault circuit interrupter) & surge protector is recommended for all electrical appliances.

13. Ensure your hands are dry when turning the power switch on/off and when inserting/removing the power cable from the socket.

14. If you are in any doubt about the electrical installation or safety of this product you must consult a qualified electrician.

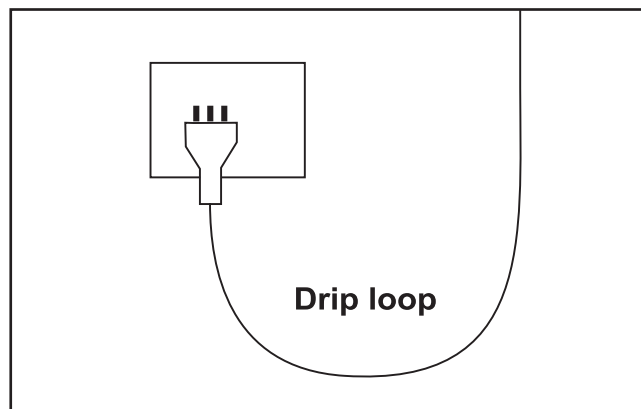

For Guarantee Conditions, please refer to the Guarantee form that is enclosed with this product.

All products are supplied with fitted plugs. This plug should not be tampered with in any way or removed. Removal or tampering with the plug invalidates our guarantee offered with this product.

For UK a 3 pin adaptor is supplied with the product and this must be used.

Before First Use / Preparation

Read and follow all the instructions, even if you feel you are familiar with the product and find a place to keep the instructions handy for future reference. Your attention is drawn particularly to the sections concerning “**IMPORTANT SAFEGUARDS**” and the “**GUARANTEE CONDITIONS**”. Please ensure you retain your original purchase receipt in the event that guarantee service is required.

Carefully unpack the aquarium making sure you keep all the packing material until all the parts of the product have been found and the product has been assembled.

This product is shipped to you in a factory sealed carton. Should the product malfunction in any way or if the unit is damaged and requires replacement, contact the retailer where the product was purchased for inspection.

Replacement Parts & Filter Media

Use Aqua One Genuine Spare Parts Only. See your local Aqua One Dealer and refer to the spare part numbers listed in the instructions supplied with the accessories. Alternatively you will find these numbers on the silver label located on electrical items.

Recommended extras

Available to purchase separately

We recommend you use Aqua One Filter Sock, Protein skimmer, Return Pump and Heaters with your MiniReef. See your local Aqua One Dealer and refer to the order numbers listed below for more information if you wish to purchase these.

Aqua One Filter Sock - **50104**

ReefSkim Protein Skimmer 300 - **50037**

PHX 200 Return Pump, 1000L/hr - **11329** (MiniReef 90)

PHX 300 Return Pump, 1800L/hr - **11330** (MiniReef 120)

100W Glass Heater - **11304** (MiniReef 90)

150W Glass Heater - **11350** (MiniReef 120)

Know Your Filter

MiniReef 90

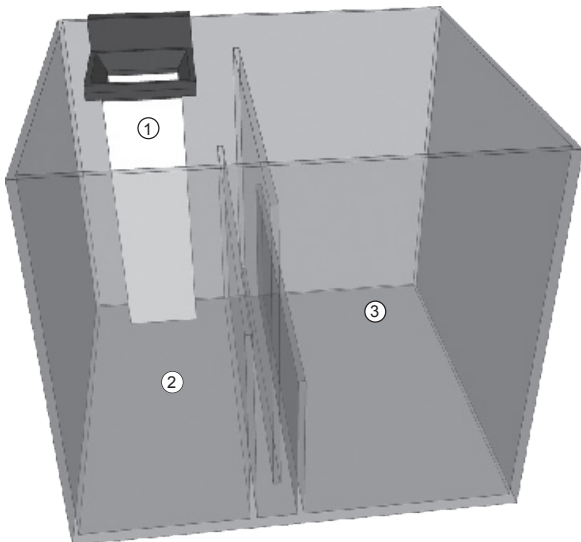

Set up/Parts

1. Filter Sock*
2. Protein Skimmer*
3. Return Pump*

MiniReef 120

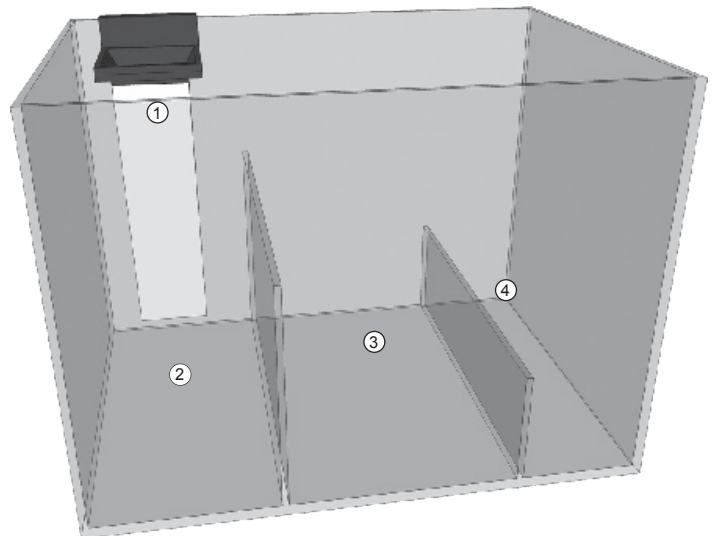

Set up/Parts

1. Filter Sock*
2. Protein Skimmer*
3. Refugium
4. Return Pump*

PLEASE NOTE: *Filter Sock, Protein Skimmer, Return Pump and Heater are not included. These are available to purchase separately. See info above for recommended products.



Set Up Instructions

Your aquarium will be in 2 separate boxes, one will contain the aquarium and light unit*, the other will contain the cabinet with sump in place and the plumbing components. Place the cabinet in position and carefully place the aquarium on the cabinet. Ensure the aquarium is centered on the cabinet.

The protein skimmer** mounts externally on the left hand side of the sump. Refer to the instructions supplied with the protein skimmer**, heater** and return pump** for installation.

A glass lid is provided.

PLEASE NOTE: *Light unit instructions will be included in the individual light unit box. Please refer to these for the light set up.

****Protein Skimmer, Return Pump and Heater are not included. These are available to purchase separately. See info on previous page for recommended products.**

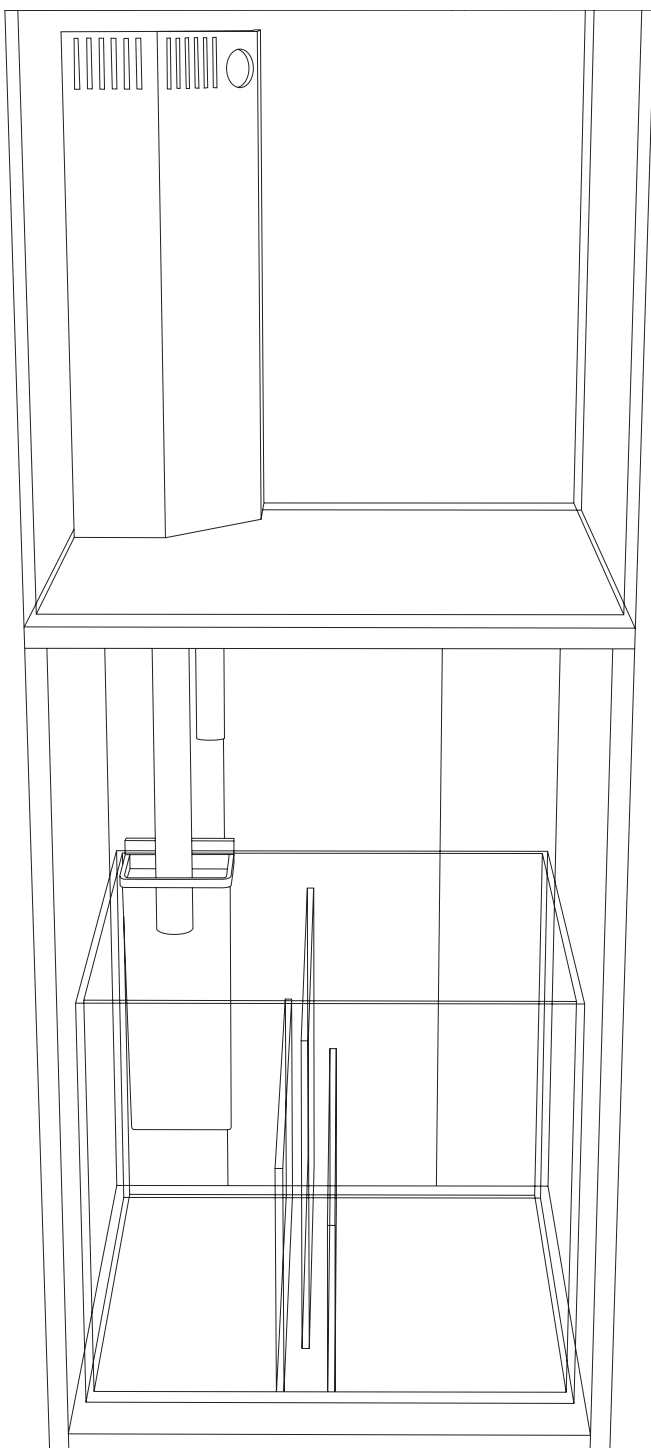

All plumbing components are already glued into place except where threaded joints are required for assembly into the aquarium or to allow access for maintenance. Two people may be required to connect the plumbing through the base of the aquarium, one to access from above the weir and one to hold pipes in place below the aquarium.

1. Insert the threaded end of the drain pipe (1) into the larger hole in the base of the weir. Ensure the rubber grommet is placed between the glass and the connection.

2. Attach the lower drain bulkhead (2) to the male thread beneath the aquarium. Ensure a rubber grommet is in place beneath the glass. Do NOT overtighten, hand tightened is sufficient.

3. Repeat step 1 and 2 with the return pipes (5 & 6). Ensure rubber grommets are used on both sides of the glass and the threaded elbow at the top of the return pipe is facing towards the round hole in the overflow.

4. Ensure the sump is on the far left hand side of the cabinet so that the drain pipe sits directly over the sump inlet. Attach the bottom section of the drain (3) by connecting the barrel union.

5. Attach the flexible outlet (4) to the return pipe. The threaded section should pass through the round hole in the overflow grill.

6. Ensure the hole in the top of the drain pipe remains free, this will minimise noise caused as water exits the aquarium.

7. Follow the instructions provided with the return pump to install into the sump. Place the pump in the position noted on page 4 and use the elbow intake as described in the instructions. A short length of flexible hose is provided to connect the pump to the return pipe (6). A hose clamp is also provided to secure the hose onto the pipe.

8. Unpack the filter sock (available separately) and place it in the location shown on page 4.

9. Fill the aquarium with water such that the water overflows into the sump and fills the last section (where the return pump* sits) to about 5cm above the **maximum operating water level** mark. When running, the water level should always remain above the minimum operating water level mark.

10. Unpack and install the protein skimmer in the left hand side of the sump. Follow the instructions supplied with the skimmer.

11. Unpack and install the heater* in the sump in the same section as the protein skimmer. Ensure the heater is fully submerged at all times.

NOTE: Plumbers tape is supplied on threaded fittings; it is highly recommended that this be replaced if the plumbing is disconnected at any time.

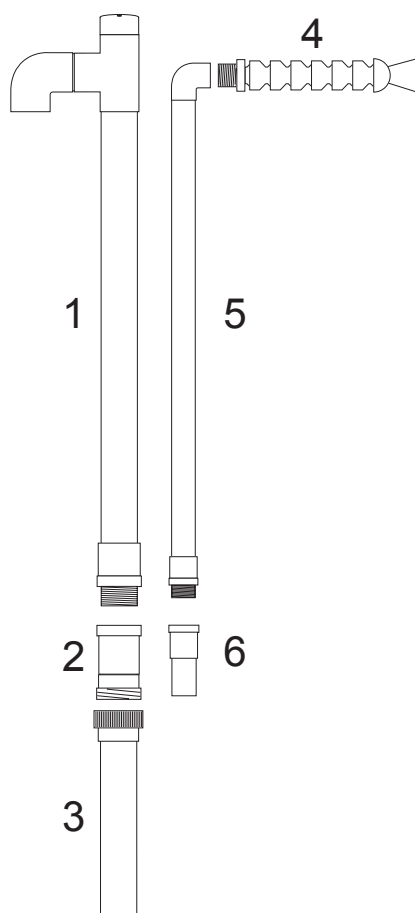



Maintenance

For maintenance instructions regarding the return pump and skimmer refer to the instruction booklet provided with the pump and skimmer.

DAILY:

Feed your fish as per instructions on your fish food container.

Check temperature

Ensure all equipment is running correctly.

Ensure water level is safely above the **minimum operating water level** mark. When topping up evaporated water, always use dechlorinated tap water or suitably filtered water. When water evaporates from the aquarium, salt remains in the water so topping up with salt water will increase the salinity of the aquarium. Check salinity after topping up.

WEEKLY:

Test water parameters including pH, ammonia, nitrite, nitrate, phosphate, carbonate hardness and specific gravity (salinity). If you are keeping coral or other sensitive marine animals you may wish to perform further testing. Seek advice from your marine aquarium specialist.

Use quality test kits, Aqua One have a range of test kits (sold separately) which will allow you to easily and accurately monitor your water quality.

Some species require specific water conditions. Please seek advice from your marine aquarium specialist.

FORTNIGHTLY: 25% water change

What you will need: A bucket, gravel cleaner, towel, algae scraper, water conditioner and either synthetic salt or premixed/natural salt water. The fish and corals do not need to be removed while performing a water change.

1. Wash your hands.
2. Mix up your salt water according to the directions on the packaging of the salt mix. Or, have your premixed/natural salt water ready.
3. Check the pH, temperature and specific gravity of both the aquarium water and the new water. Make any adjustments that need to be made to the new water. You may want to purchase a second heater to warm the new water.
4. Once the water is ready to use, remove the light unit and glass lids and place them somewhere safe away from the water where they will not be broken or damaged.
5. Turn the heater and pump off.
6. Place a towel on the floor in front of the aquarium to guard from water spillage.
7. Use an algae scraper and gently remove any algae that is growing on the glass.
8. Using a gravel cleaner, remove 25% of the aquarium water. Take note of how much water is removed and be sure to have enough prepared water to replace all that is removed.
9. Refill the aquarium using the prepared water to approximately 10cm above the **minimum operating water level** mark.
10. Turn the heater and pump back on and ensure the water level is safely above the **minimum operating water level** mark.
11. Allow the aquarium to run for 30 minutes then check the temperature, specific gravity and pH. Adjust if necessary.
12. Replace the glass lids and light unit.

Trouble Shooting

BUBBLES ARE COMING OUT THE OUTLET INTO THE AQUARIUM

1. The water level in the sump is too low. Check specific gravity after topping up to the correct level.
2. The elbow has become loose or come off the pump inlet.

WATER FLOW INTO THE AQUARIUM HAS DROPPED

1. Pump needs to be cleaned. Refer to maintenance instruction provided with pump.
2. Outlet is blocked. Remove and clean the flexible outlet.

DRAIN PIPE IS MAKING A GURGLING NOISE

1. Air intake may be blocked. Remove and rinse in fresh water, salt build up can cause a small blockage
2. There is a blockage in the drain pipe. Remove air intake and check pipe for blockage.

Specifications

Aquarium Model: MiniReef 90
Overall Dimensions (exc. light): 45 x 45 x 125cm
Aquarium Volume: 90L
Glass Thickness: 8mm
Suitable: Marine

Aquarium Model: MiniReef 120
Overall Dimensions (exc. light): 60 x 45 x 125cm
Aquarium Volume: 120L
Glass Thickness: 8mm
Suitable: Marine

Light Unit Specifications

Please refer to the light unit instructions for all the necessary spec and set up information. These will be included inside the light unit box.

Recommended extras

Available to purchase separately

We recommend you use Aqua One Filter Sock, Protein skimmer, Return Pump and Heaters with your MiniReef. See your local Aqua One Dealer and refer to the order numbers listed below for more information if you wish to purchase these.

Aqua One Filter Sock - **50104**
ReefSkim Protein Skimmer 300 - **50037**
PHX 200 Return Pump, 1000L/hr - **11329** (MiniReef 90)
PHX 300 Return Pump, 1800L/hr - **11330** (MiniReef 120)
100W Glass Heater - **11304** (MiniReef 90)
150W Glass Heater - **11350** (MiniReef 120)

Correct Disposal of this product



This marking indicates that this product should not be disposed with other household waste throughout the EU. To prevent harm to the environment or human health from uncontrolled waste disposal, recycle it responsibly to promote the sustainable reuse of material resources. To return your used device, please use the return and collection systems or contact the retailer where the product was purchased. They can take this product for environmental safe recycling.



Aqua One Manufacturers Guarantee 1 + 1 Year

The additional 1 Year **Extended Guarantee** applies when you REGISTER online with Aqua One. Register your Extended Guarantee at www.aquaone.com.au

The Aqua One Aquarium purchased must be installed upon a level surface and weight bearing cabinet and there upon level and load bearing flooring (using a level is recommended). The purchaser must consider the total weight of all items when installing an Aquarium which could be up to 1200kg dependant on the model and accessory items chosen. Consider this, 1L of water = 1kg weight.

About this Guarantee

The Manufacturer or Distributor, of Aqua One goods, is collectively known herein as "Aqua One". Please refer to contact details for Aqua One below or on the applicable Aqua One website. Any product that is covered by its own Guarantee (as enclosed with the product) is subject to the conditions of that Guarantee.

Australian Guarantee

Important note: This guarantee applies in addition to the guarantees, rights and remedies conferred by the Australian Consumer Law and other applicable Commonwealth, State and Territory legislation. The guarantee does not exclude, affect or limit those guarantees, rights or remedies, except to the extent that their application may lawfully be excluded or limited.

In particular, our goods come with guarantees that cannot be excluded under the Australian Consumer Law. You are entitled to a replacement or refund for a major failure and for compensation for any other reasonably foreseeable loss or damage. You are also entitled to have the goods repaired or replaced if the goods fail to be of acceptable quality and the failure does not amount to a major failure.

International Guarantee

The benefits given to the purchaser, under Guarantee, are in addition to all other statutory rights and remedies which the purchaser has in respect of goods under legislation in the applicable country of purchase. This Guarantee shall not affect any such rights and should be read subject to such legislation.

1.0. Terms and Conditions of Guarantee.

- 1.1. Aqua One warrants to the purchaser, for 1 Year from date of original purchase, to repair or replace goods where fault is found due to defective materials or faulty workmanship and where goods do not operate in accordance with the instructions.
- 1.2. All claims for repair or replacement must be made at place of purchase.
- 1.3. The original and dated Proof of Purchase (receipt) must be supplied with all goods claims. Please also provide this Guarantee where possible.
- 1.4. The Guarantee covers the Aquarium against gluing breakdown resulting in leakage.
- 1.5. All goods subject to claim under Guarantee should be prepared for transportation in the original packaging or other comparable packaging which offers the same degree of protection.
- 1.6. Where goods are repaired or replaced under Guarantee, these goods are Guaranteed for the remainder of either the original Guarantee or Extended Guarantee period.
- 1.7. Where claims on inspection reveal goods are in normal working order, Aqua One will request reimbursement of all reasonable costs incurred.

2.0. Other Terms and Conditions – Extended Guarantee

- 2.1. The Extended Guarantee period is for an additional 1 Year and commences on expiration of the standard guarantee period.
- 2.2. Application for Extended Guarantee is FREE of any registration cost to the purchaser on completion of the Extended Guarantee questionnaire which is found on the applicable Aqua One website (refer below).
- 2.3. Upon receipt and acceptance of the questionnaire, Aqua One will forward (by way of email) a Certificate of Extended Guarantee to the purchaser.
- 2.4. For more information on how we collect, hold, use and disclose personal information provided to us, please refer to our Privacy Statement on the Aqua One websites or write to our Privacy Officer, in your country of purchase.
- 2.5. Where Aqua One determines goods are being used in a manner contrary to the instructions, specifications or this Guarantee, Aqua One reserves the right to terminate Extended Guarantee for such goods and will provide written notice to the purchaser.

3.0. Exclusions and Limitations

Where permitted by local law, the following exclusions and limitations apply in regard to Guarantee:

- 3.1. Glass breakage, for whatever reason caused after Aquarium purchase.
 - 3.2. Goods claims where fault is due to, but not limited by a) misuse b) neglect c) abuse d) fire or flood e) normal wear and tear f) accidental breakage g) Acts of God h) mains voltage fluctuation or supply problems i) connection to any voltage other than what is stated on the rating plate j) modification or tampering to electrical cord or plug, k) vermin, insects or foreign object l) liquid spillage or submersion of goods not designed to sustain such use or duress.
 - 3.3. Where inspections reveal goods are in normal working order including where noise or vibration is consistent with normal goods operation.
 - 3.4. Attempted repairs or modifications by unauthorised persons, including but not limited to the drilling of holes in the aquarium glass by unauthorised persons.
 - 3.5. Where the goods factory rating plate has been removed, altered, damaged or is rendered illegible.
 - 3.6. Where goods are not installed, operated or maintained in accordance with Aqua One's goods instructions, specifications or this Guarantee.
 - 3.7. Replacement or repair of worn consumables or replacement of lost goods, parts or components.
 - 3.8. Costs associated with goods transportation, removal, installation, postage or cost of insurance.
 - 3.9. Any damage incurred whilst installing, transporting or moving the goods.
 - 3.10. Subject to certain local statutory rights and obligations to the contrary, and this guarantee shall not affect those rights or obligations, where, to the full extent permitted by law: 1. all express and implied warranties and conditions under statute or general law, are expressly excluded and Aqua One, where permitted, will limit liability as follows and at Aqua One's option to: in regard to goods either a) the replacement of goods or supply of equivalent goods b) the repair of goods or the cost of replacing the goods or of acquiring equivalent goods OR in regard to services either c) the re-supply of services d) the cost to re-supply services.
2. Aqua One will not be liable for any loss or damage, including consequential loss or damage either directly or indirectly, or for any incidental expenses, of any kind, and in any way whatsoever.

(1) we recommend the use of an Aqua One Cabinet (sold separately) as specially designed to suit the Aqua One Aquarium purchased.

(2) consider total weight of all items such as: Aquarium, cabinet, water, filtration, gravel/substrate, decorations and other equipment.

(3) consumables include items such as filter media/cartridges, impellers and shafts, light tubes, lamps, bulbs and starters.

(4) due to the extremely fragile nature of glass and glass being the main component of an Aqua One Aquarium, we strongly recommend that you advise your insurer and consider adding this item to your policy.

(5) When moving the Aquarium from its original or subsequent set-up location/s the following should be adhered to prior to moving the aquarium: remove all aquatic fish, animals or plants, filtration, gravel/substrate, decorations, other equipment mounted on or in the aquarium and ALL water. Also separate the Aquarium from the Aquarium cabinet or similar household item.

Aqua One may be contacted in:

Australia
Kong's (Aust.) Pty. Limited
PO Box 863, Ingleburn
1890 NSW Australia
www.aquaone.com.au

Hong Kong
Kong's Aquarium Supplies Co., Ltd
No 31, 3/F Thriving Industrial Centre
26-38 Sha Tsui Road, Tsuen Wan,
Hong Kong
www.aquaone.co.hk

New Zealand
Kong's (NZ) Limited
PO Box 15 - 183, Tauranga
3015 New Zealand
www.aquaone.co.nz

United Kingdom
Kong's (UK) Limited,
C/O Aqua Pacific UK Ltd.
Unit 1 Mauretania Road
Nursling Industrial Estate
Hampshire, SO16 0YS
United Kingdom
www.aquaone.co.uk

This Aquarium is designed to help simplify general fish keeping. Please note, some specialist fish and aquatic animal or plant keeping require certain considerations, prior to purchase, to ensure proper and successful Aquarium keeping. Therefore, **Aqua One recommends, at time of Aquarium purchase, that you consult with your Aqua One Retailer in regard to the suitability of this product for the types of fishes, aquatic animals or plants you may wish to keep.** Special consideration should also be made in regard to filtration, aquarium heater and lighting requirements to ensure they are specific to your application.