

# Assembly Instructions

Please keep for future reference

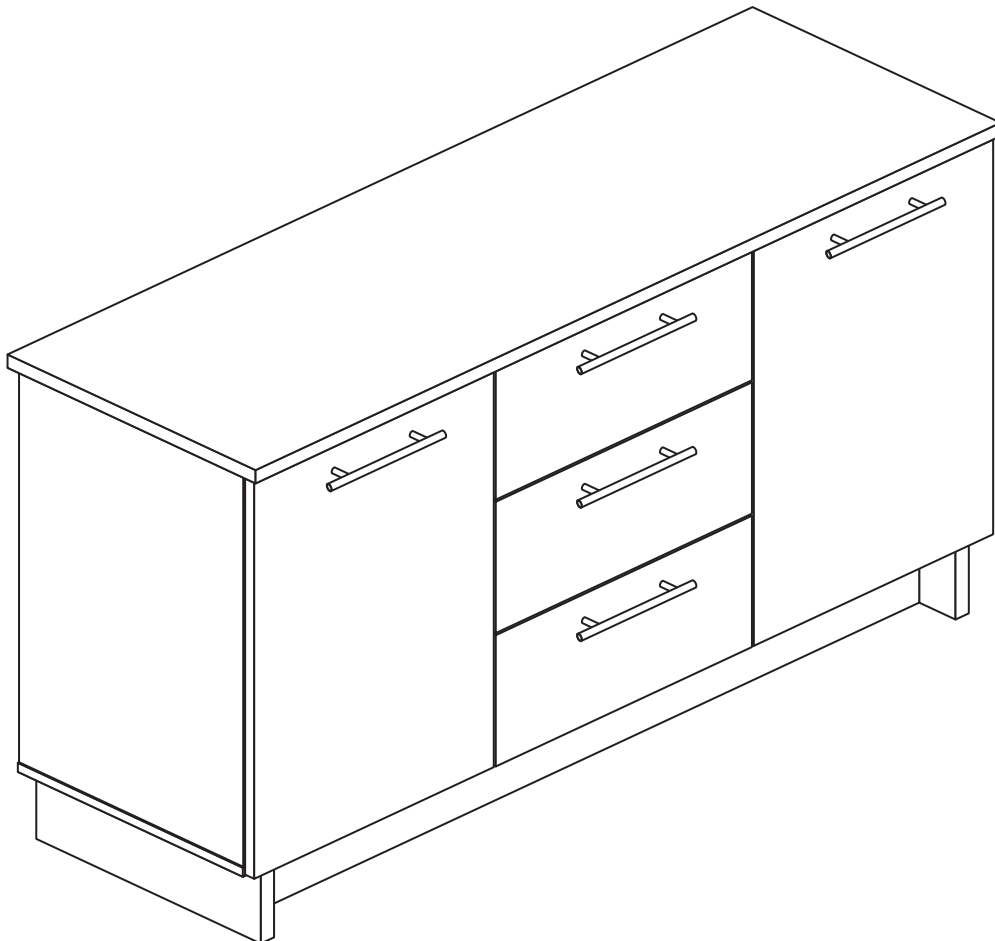

## Oakstyle Chic 3+2 Unit



Version 1 : 21/07/2020

Important - Please read these instructions fully before starting assembly

ALR3664

# Safety and Care Advice

**Important - Please read these instructions fully before starting assembly**

- Warning: This unit is heavy. Please lift with care.

- Check you have all the components and tools listed.

- Remove all fittings from the plastic bags and separate them into their groups.

- Keep children and animals away from the work area, small parts could choke if swallowed.

- Parts of the assembly will be easier with 2 people.

- Make sure you have enough space to layout the parts before starting.

- Assemble the item as close to its final position (in the same room) as possible.

- Assemble on a soft level surface to avoid damaging the unit or your floor (use opened out unit carton).



- We do not recommend the use of power drill/drivers for inserting screws, as this could damage the unit. Only use hand screwdrivers.

- **Safety note: This unit must be secured to a wall using the overbalance protector kits supplied.**

- Dispose of all packaging carefully and responsibly.

## Care and maintenance

- Only clean using a damp cloth and mild detergent, do not use bleach or abrasive cleaners.

- From time to time check that there are no loose screws on this unit.

- This product should not be discarded with household waste. Take to your local authority waste disposal centre.

## Contact Us

Aqua Pacific UK Ltd.  
Unit 10, Oriana Way  
Nursling Industrial Estate  
Southampton  
SO16 0YU

Tel +44 (0) 2380 734000  
Fax +44 (0) 2380 740200  
Sales@aquapacific.co.uk

### Tools



Rule

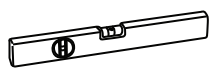

Spirit level



Cross-head screwdriver



Flat-head screwdriver



Scissors



Hammer



Eye protection  
(when using a hammer or drill)



Electric drill  
(do not use for fitting screws)

# Panels

Please check you have all the panels listed below

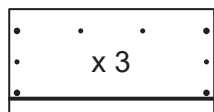

**1** Drawer Front  
(DF-00023486)  
(42.35 x 21.7cm)

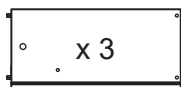

**2** Left Drawer Side  
(WRP-00000081)  
35 x 16.5cm

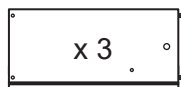

**3** Right Drawer Side  
(WRP-00000082)  
35 x 16.5cm

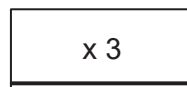

**4** Drawer Back  
(WRP-00000376)  
37.9 x 16.5cm

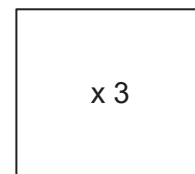

**5** Drawer Base  
(TDF-00020388)  
39 x 34.7cm

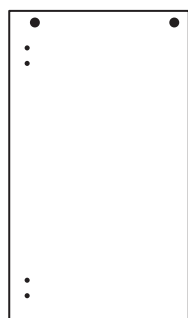

**6** Left Side  
(DF-00023494)  
(64.5 x 37.1cm)

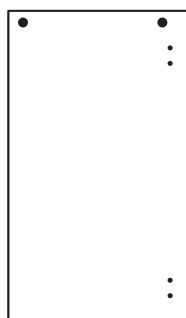

**7** Right Side  
(DF-00023493)  
(64.5 x 37.1cm)

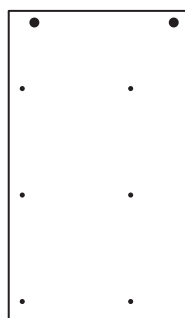

**8** Left Divider  
(DF-00023498)  
(64.5 x 37.1cm)

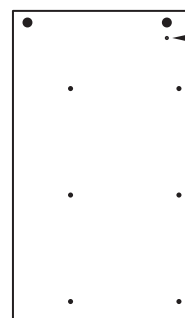

**9** Right Divider  
(DF-00023497)  
(64.5 x 37.1cm)

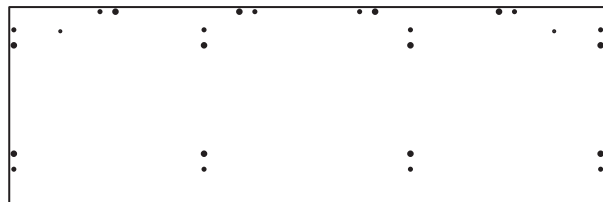

**10** Top (DF-00020378)  
(123.15 x 41cm)

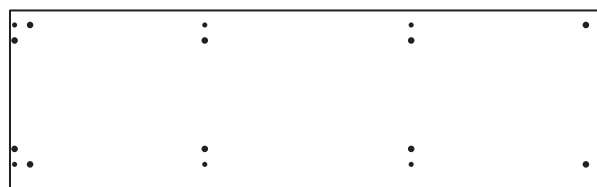

**11** Base (DF-00020379)  
(123.15 x 37.2cm)

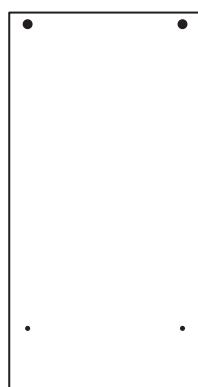

**12** Back Panel (DF-00020353)  
(78.5 x 39.6cm) x 2

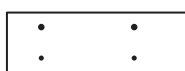

**13** H-Frame LH Upright  
(DF-00021046)  
(37.1 x 12.5cm)

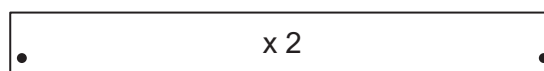

**15** H-Frame Cross Rail (DF-00021047)  
(112.65 x 12.5cm)

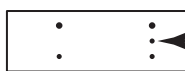

**14** H-Frame RH Upright  
(DF-00021249)  
(37.1 x 12.5cm)

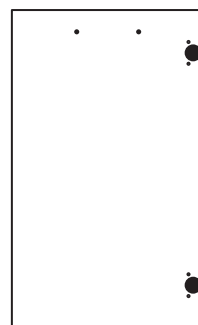

**16** LH Door  
(DF-00023484)  
(65.7 x 39.6cm)

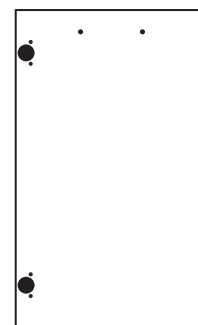









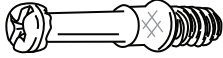

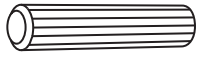
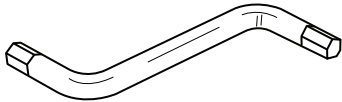
**17** RH Door  
(DF-00023487)  
(65.7 x 39.6cm)

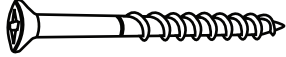





# Fittings

Please check you have all the fittings listed below

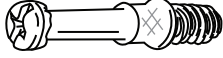

## Bag 1

<p><b>A</b> </p> <p>Large Metal Dowel (F901) x 16</p>	<p><b>B</b> </p> <p>Large Locking Cam Nut (F900) x 16</p>	<p><b>C</b> </p> <p>Wooden Dowel (F22) x 24</p>
<p><b>D</b> </p> <p>Allen Key (F36) x 1</p>	<p><b>E</b> </p> <p>50mm Screw (F49) x 4</p>	<p><b>F</b> </p> <p>40mm Screw (F910) x 8</p>
<p><b>G</b> </p> <p>45mm Screw (F65) x 4</p>	<p><b>H</b> </p> <p>13mm Screw (F63) x 8</p>	<p><b>I</b> </p> <p>9mm Screw (F73) x 12</p>
<p><b>J</b> </p> <p>20mm Screw (F461) x 4</p>	<p><b>K</b> </p> <p>Door Buffers (F137) x 6</p>	<p><b>L</b> </p> <p>Shelf stud (F110) x 6</p> <p>★ These are for fixing the Hood. See separate instructions for fitting details.</p>

## Bag 2

<p><b>A</b> </p> <p>Large Metal Dowel (F901) x 6</p>	<p><b>J</b> </p> <p>20mm Screw (F461) x 4</p>	<p><b>M</b> </p> <p>Small Locking Cam Nut (F900) x 6</p>
<p><b>N</b> </p> <p>Knock-in Peg (F171GY) x 12</p>	<p><b>O</b> </p> <p>9mm Screw (F74) x 6</p>	<p><b>P</b> </p> <p>Back Holder (F639) x 12</p>

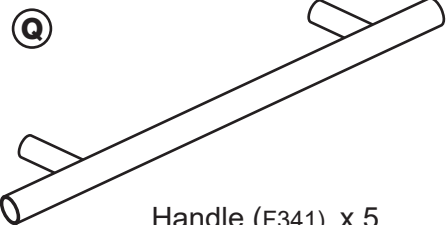
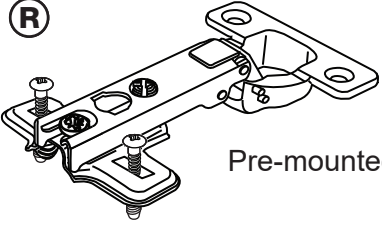
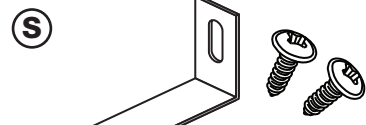
## Individual Bags

<p><b>Q</b> </p> <p>Handle (F341) x 5</p>	<p><b>R</b> </p> <p>Pre-mounted hinge (F328) x 4</p>
<p><b>S</b> </p> <p>Overbalance protector kit (F474) x 2</p>	<p><b>T</b> </p> <p>Drawer runner (F1004) x 6</p>

## Step 1

### Prepare the 3 Drawer Fronts

Screw 2 Metal Dowels into each Drawer Front.

Note: Tighten the Metal Dowels up fully against the panel.

Stick a door buffer into the top corners of each Drawer Front.

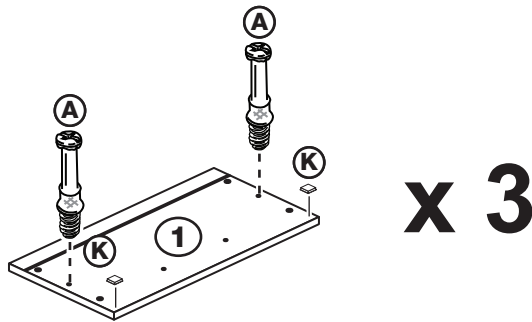

## Step 2

### Prepare the 3 pair of Drawer Sides

Insert a Small Locking Cam Nut into each Left Drawer Side and each Right Drawer Side.

Note: The arrow on the Small Locking Cam Nut must point towards the hole in the edge of the panel.

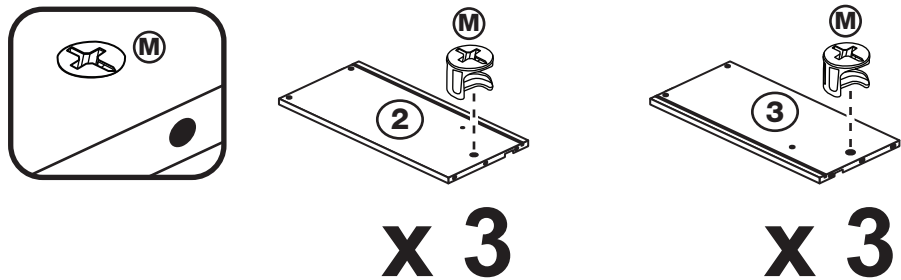

## Step 3

### Attach the Drawer Sides to the Drawer Fronts

Push the Drawer Sides onto the back of the Drawer Fronts.

Turn the Small Locking Cam nuts on the Drawer Sides.

**Note:** Turn the Small Locking Cam nuts clockwise to secure the panels - more than 1/2 a turn.

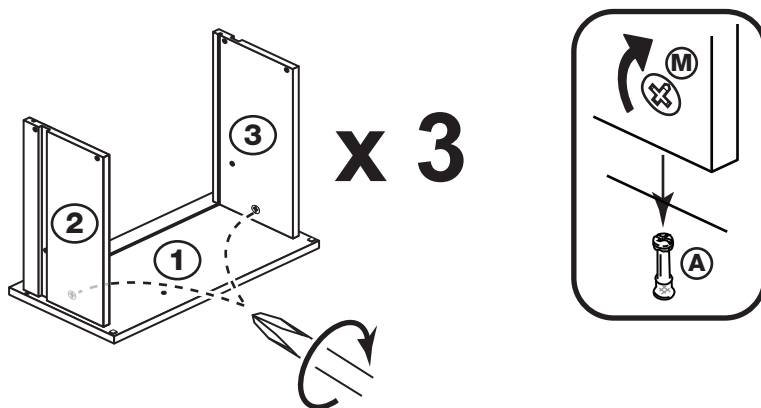

## Step 4

### Fit the Drawer Bases

Slide the Drawer Base down the grooves in the Drawer Sides and down into the groove in the Drawer Front.

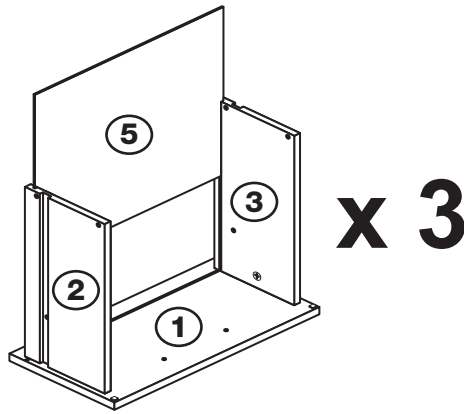

## Step 5

### Fit the Drawer Backs

Fit the Drawer Back between the Drawer Sides.

Make sure that the Drawer Base fits into the groove in the Drawer Back.

Hold the Drawer Back in position and tap the Knock-in Pegs through the holes in the Drawer Sides.

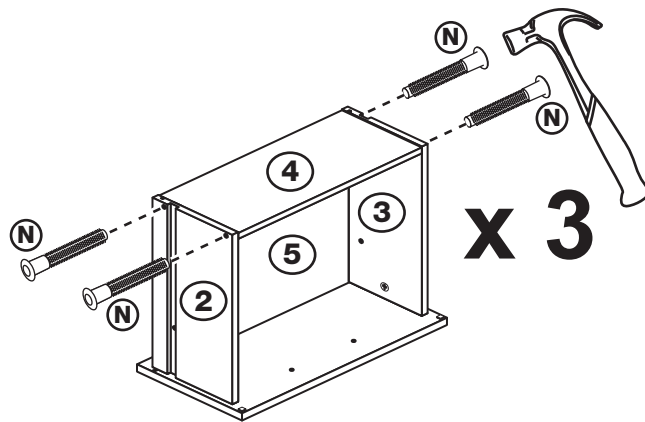

## Step 6

### Attach the Handles

Attach a Handle to each Drawer Front using two 20mm Screws from Bag 1.

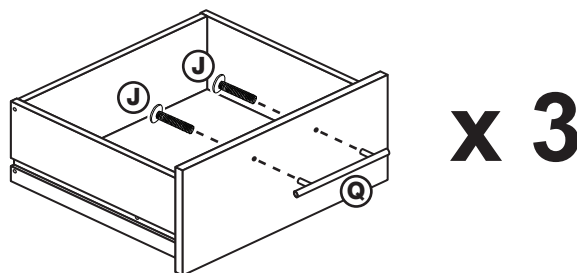

## Step 7

### Fit the Wedgefixes

Turn the 3 drawer assemblies over and slide 2 Wedgefixes into the front and back grooves, as shown, and tighten up the screws.

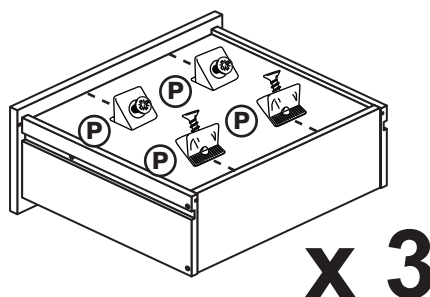

The Drawer assembly must be square before fitting the wedgefixes

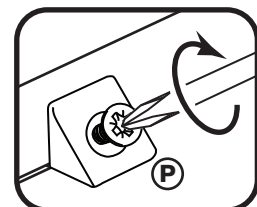

## Step 8

### Prepare the Left Divider

**a:** Place a runner on the Left Divider, as shown. Slide back the top of Runner and use the 2nd hole from the front to fit the first 9mm Screw.

**b:** Slide the Runner back the other way and fit the second 9mm Screw into the corresponding hole in the Left Divider.

**c:** Tap 2 Wooden Dowels into the Left Divider.

Insert 2 Large Locking Cam Nuts into the Left Divider.

## Use Bag 1 for steps 8 - end

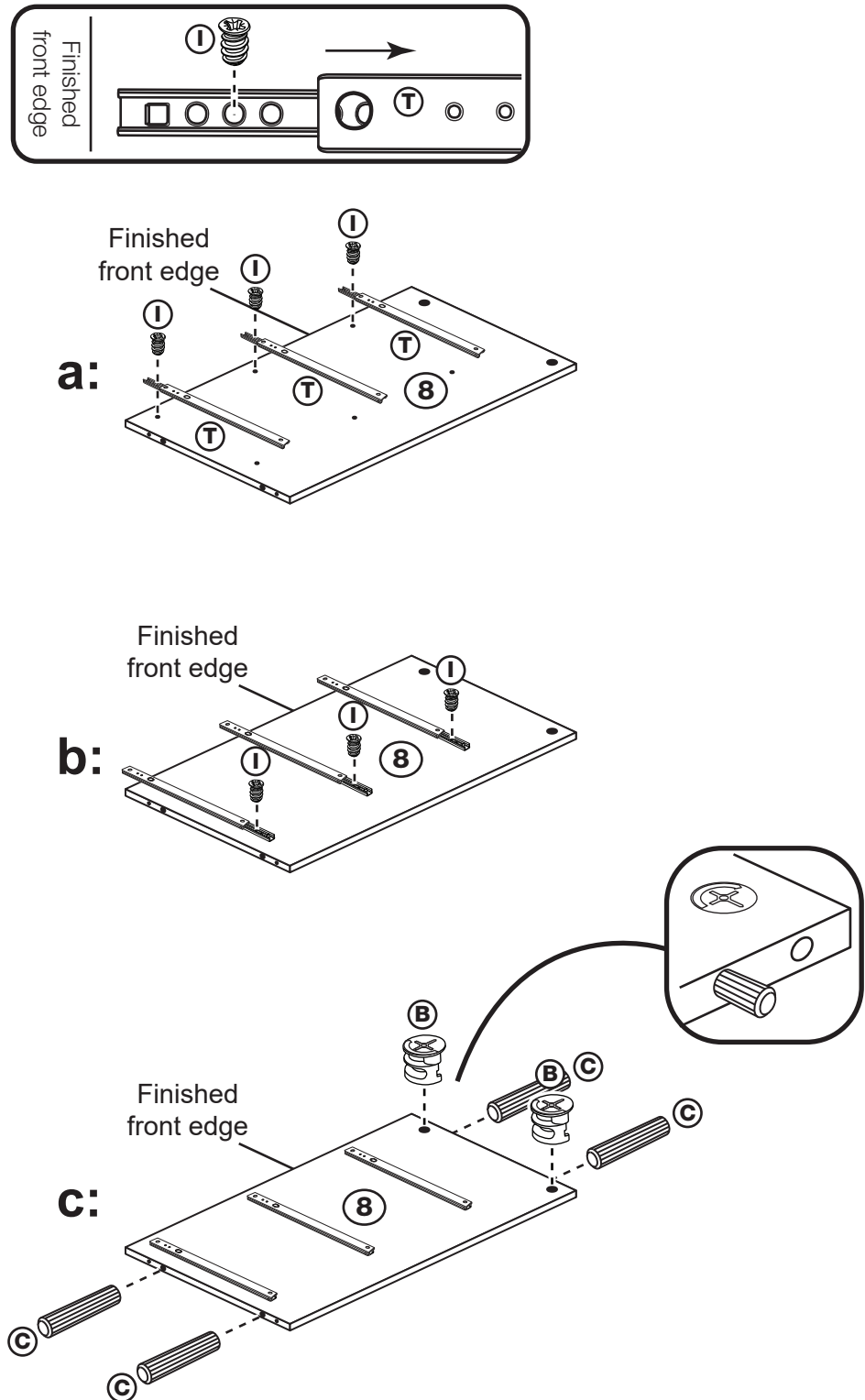

## Step 9

### Prepare the Right Divider

**a:** Place a runner on the Right Divider, as shown. Slide back the top of Runner and use the 2nd hole from the front to fit the first 9mm Screw.

**b:** Slide the Runner back the other way and fit the second 9mm Screw into the corresponding hole in the Right Divider.

**c:** Tap 2 Wooden Dowels into the Right Divider.

Insert 2 Large Locking Cam Nuts into the Right Divider.

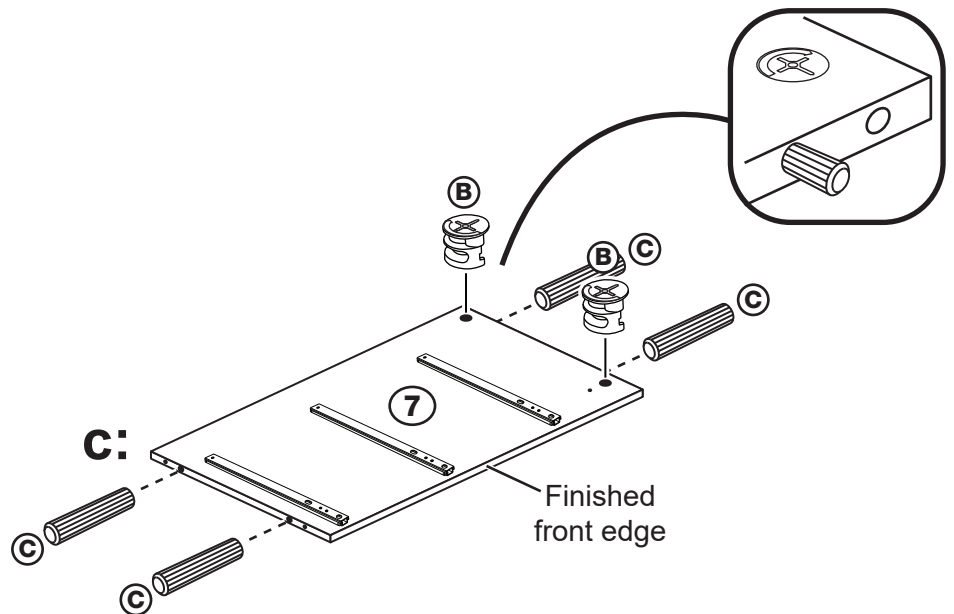
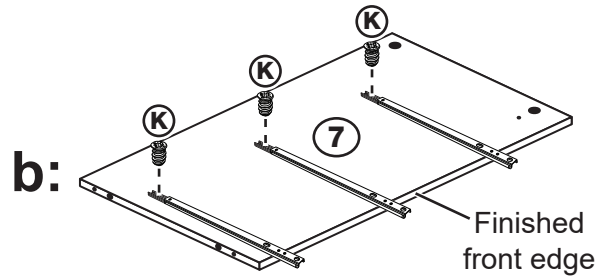
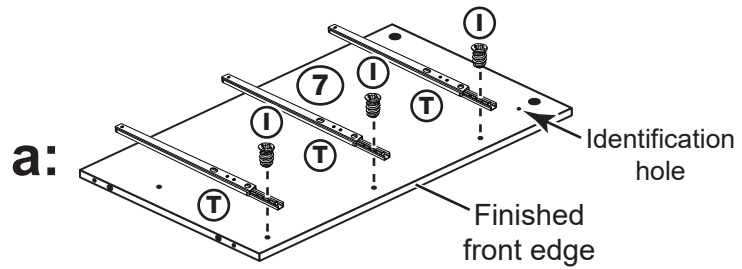
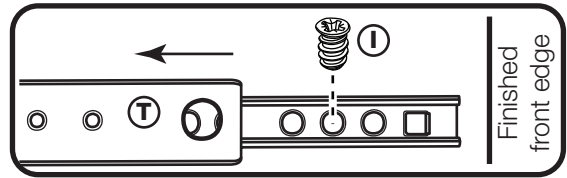



## Step 10

### Fit the Left Divider to the Base

Attach the Left Divider to the Base using two 40mm Screws.

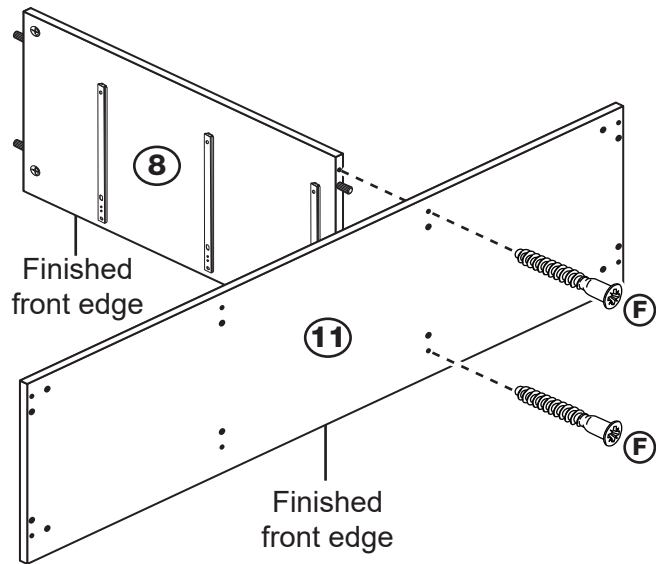

## Step 11

### Fit the Right Divider

Attach the Right Divider to the Base using two 40mm Screws.

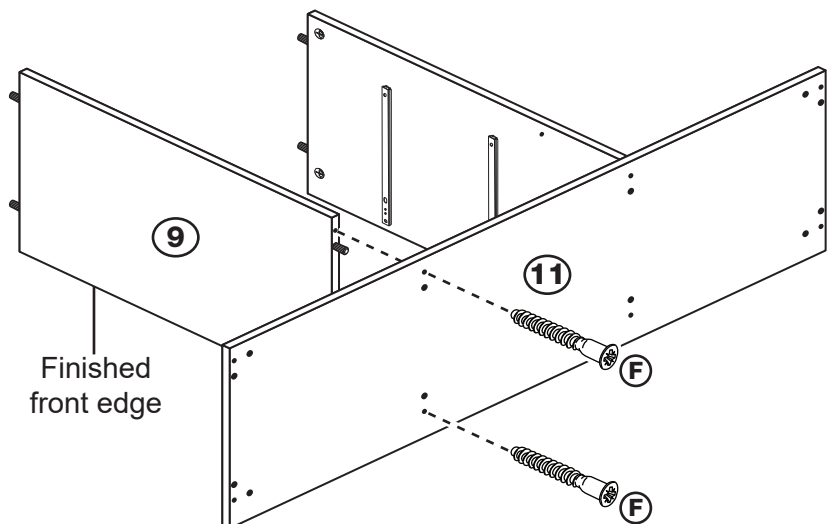

## Step 12

### Prepare the 2 H-Frame Uprights

Screw 2 Metal Dowels into the H-Frame LH Upright and the H-Frame RH Upright.

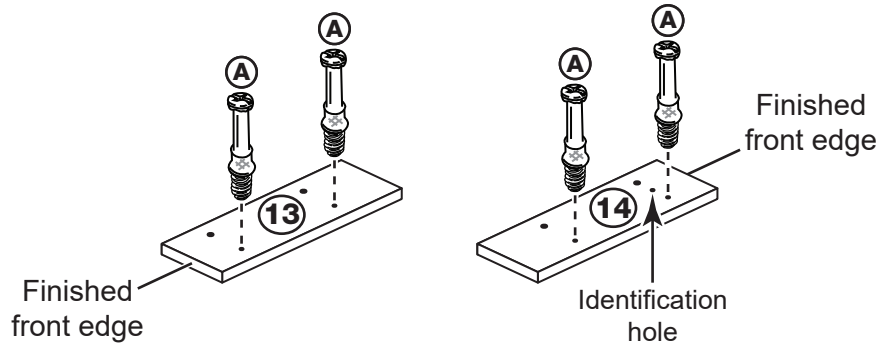

## Step 13

### Prepare the 2 H-Frame Cross Rails

Tap 2 Wooden Dowels into the H-Frame Cross Rail.

Insert 2 Large Locking Cam Nuts into the H-Frame Cross Rail.

**Note:** The arrow on the Large Locking Cam Nuts must point towards the hole in the edge of the panel.

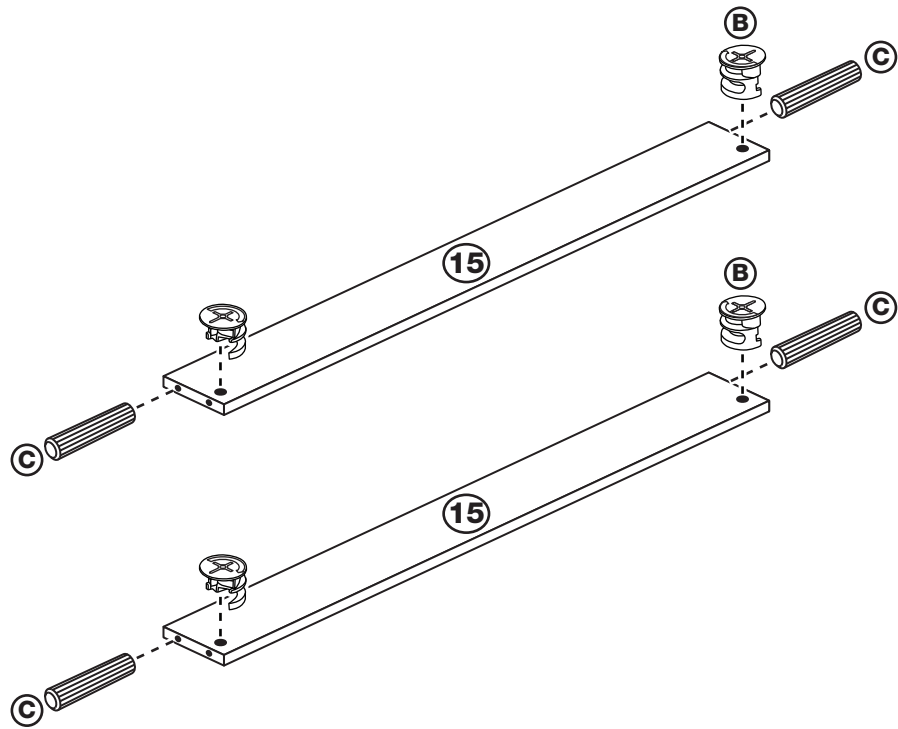

## Step 14

### Join the 2 H-Frame Cross Rails to the H-Frame LH Upright

Push the 2 H-Frame Cross Rails onto the H-Frame LH Upright.

Use a flat-head screwdriver to tighten the 2 Large Locking Cam Nuts fitted to the 2 H-Frame Cross Rails.

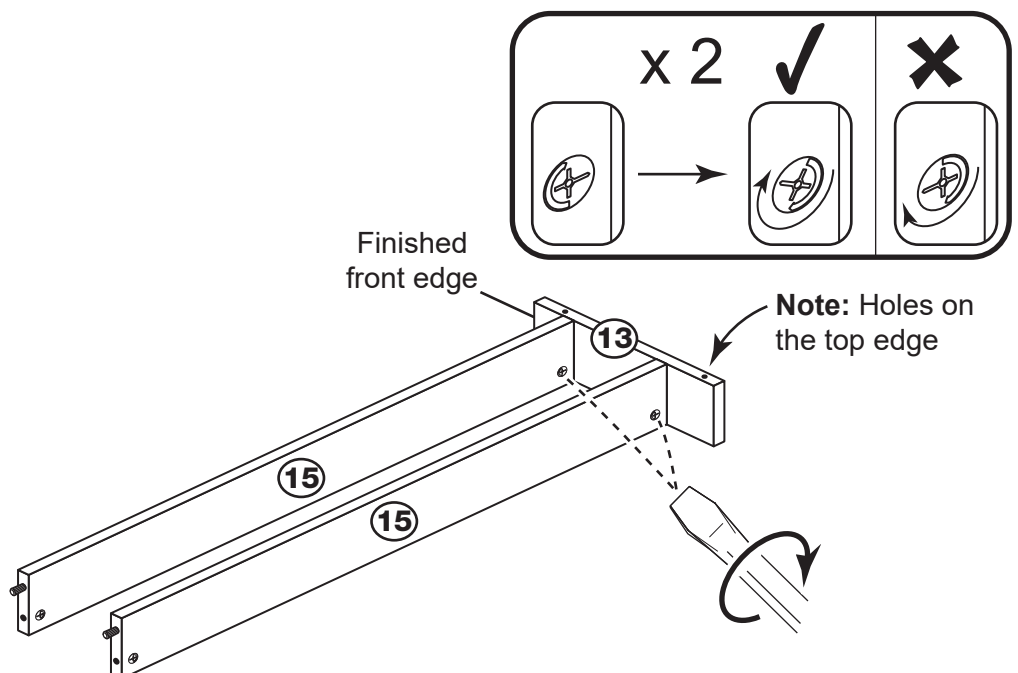

## Step 15

### Fit the H-Frame RH Upright

Push the H-Frame RH Upright onto the 2 H-Frame Cross Rails.

Use a flat-head screwdriver to tighten the 2 Large Locking Cam Nuts fitted to the 2 H-Frame Cross Rails.

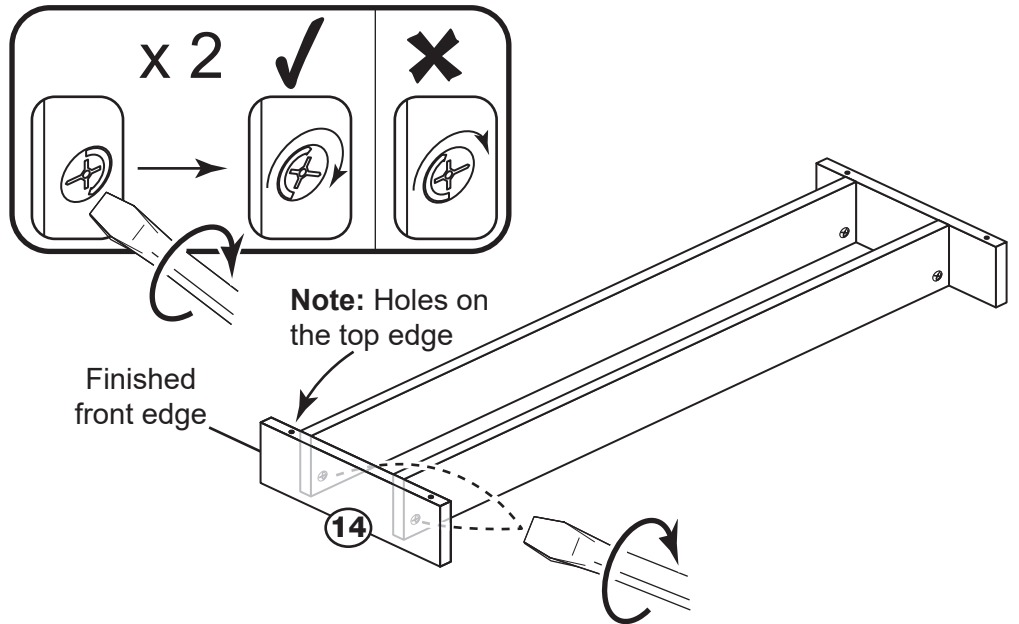

## Step 16

### Fit the H-Frame to the Base

Push the H-Frame onto the Base and secure it using four 50mm Screws and the Allen Key, as shown.

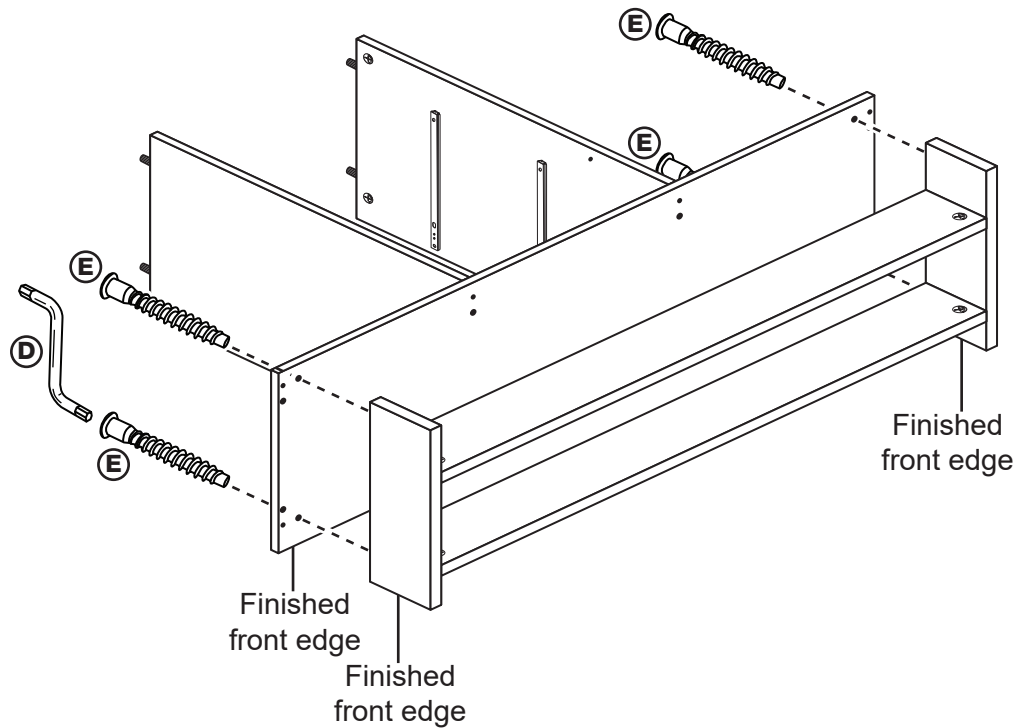

## Step 17

### Raise the assembly

To make it easier to fit the Top Panel, place packaging pieces underneath the Side Panels to raise the assembly.

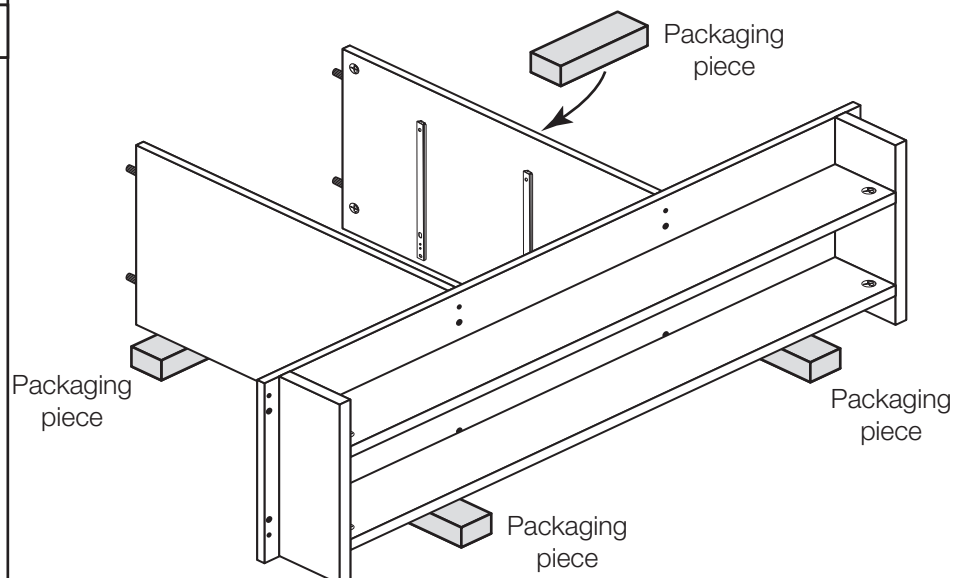

## Step 18

### Prepare the Left Side

Tap 4 Wooden Dowels into the Left Side.

Insert 2 Large Locking Cam Nuts into the Left Side.

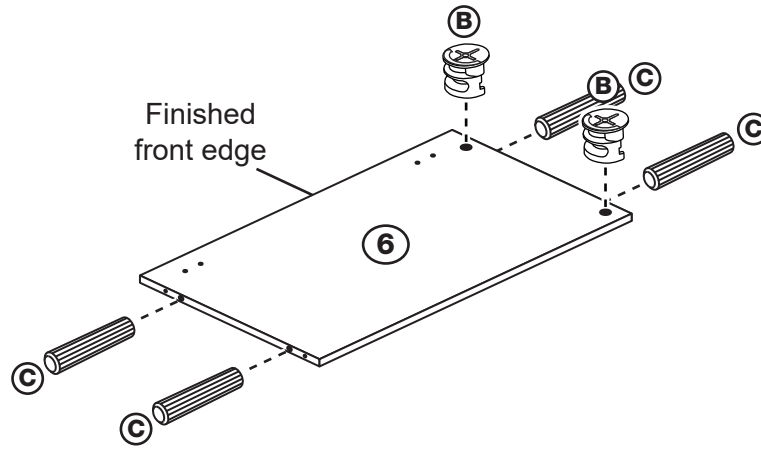

## Step 19

### Prepare the Right Side

Tap 4 Wooden Dowels into the Right Side.

Insert 2 Large Locking Cam Nuts into the Left Side.

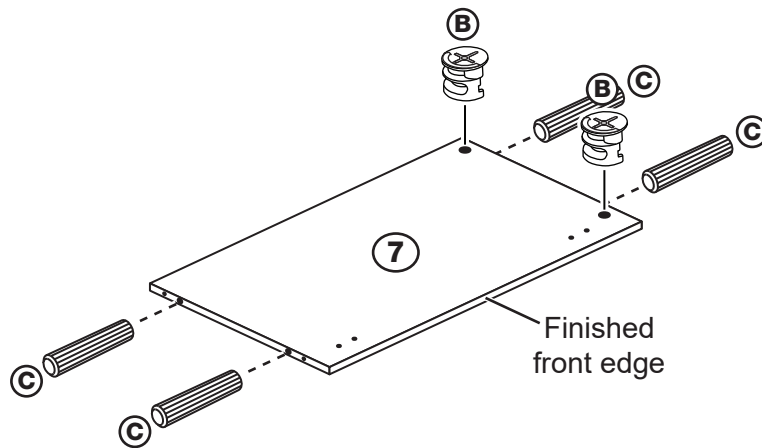

## Step 20

### Fit the Left Side and Right Side to the Base

Attach the Left Side and Right Side to the Base using four 40mm Screws.

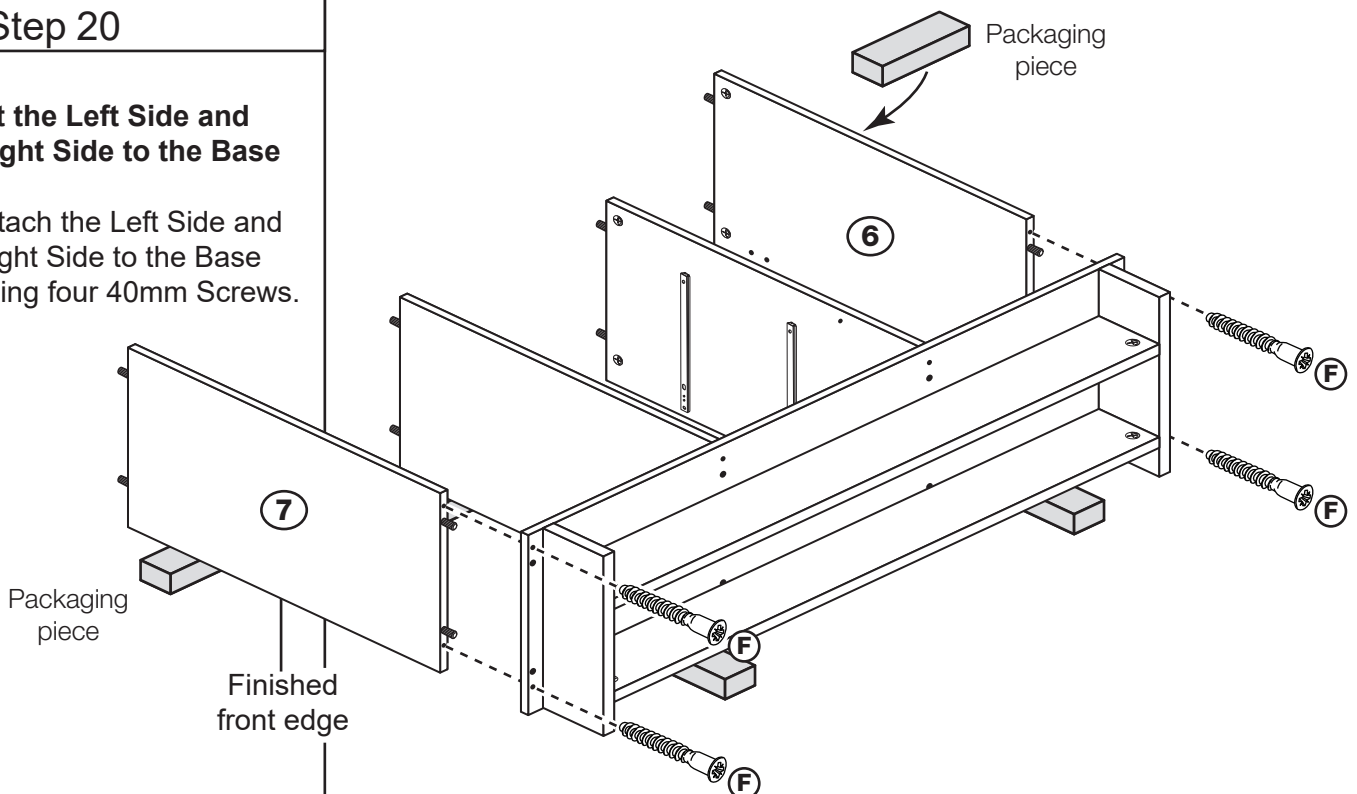

## Step 21

### Prepare the Top

Screw 8 Metal Dowels into the Top.

Fit the 2 Brackets from the Overbalance Protector Kit to the shallow mark-holes drilled into the Top using 1 of their Screws.

**Note:** Only fit 1 of the Screws, the other 1 will be fitted later.

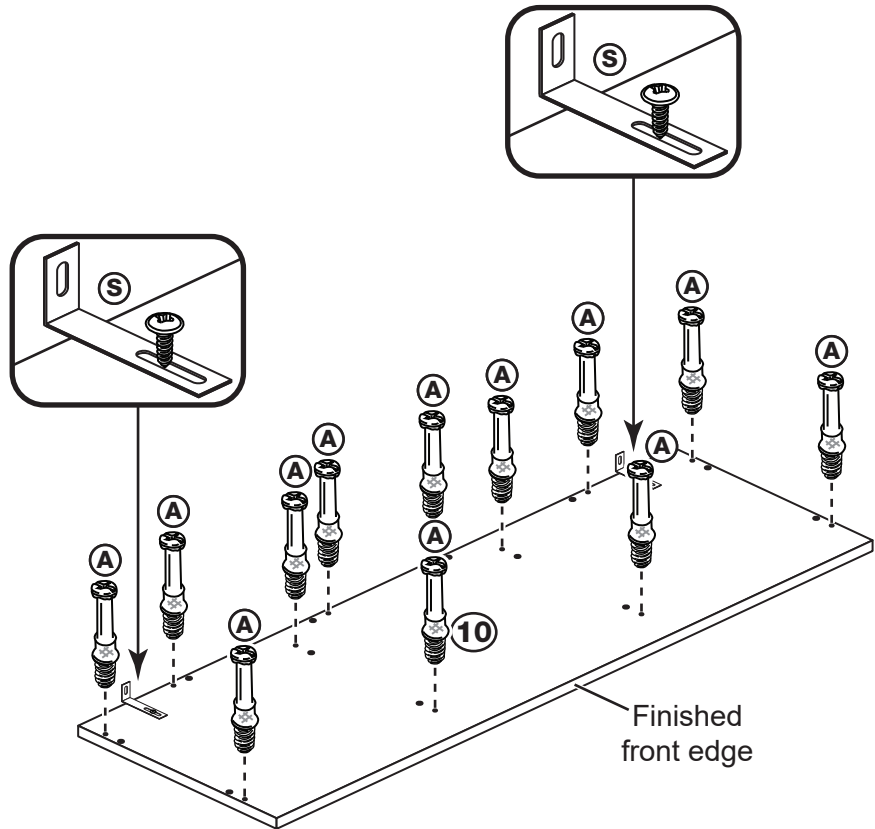

## Step 22

### Fit the Top

Push the Top Panel onto the 2 Side Panels.

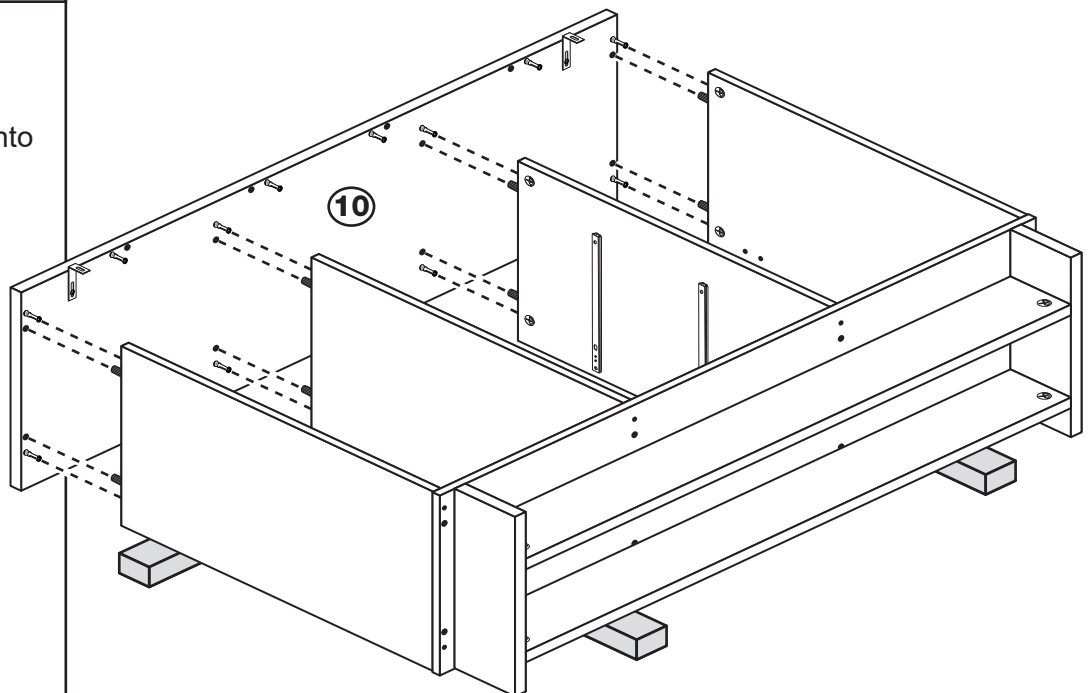

## Step 23

### Secure the Top

Use a flat-head screwdriver to tighten the 8 Large Locking Cam Nuts fitted to the Sides.

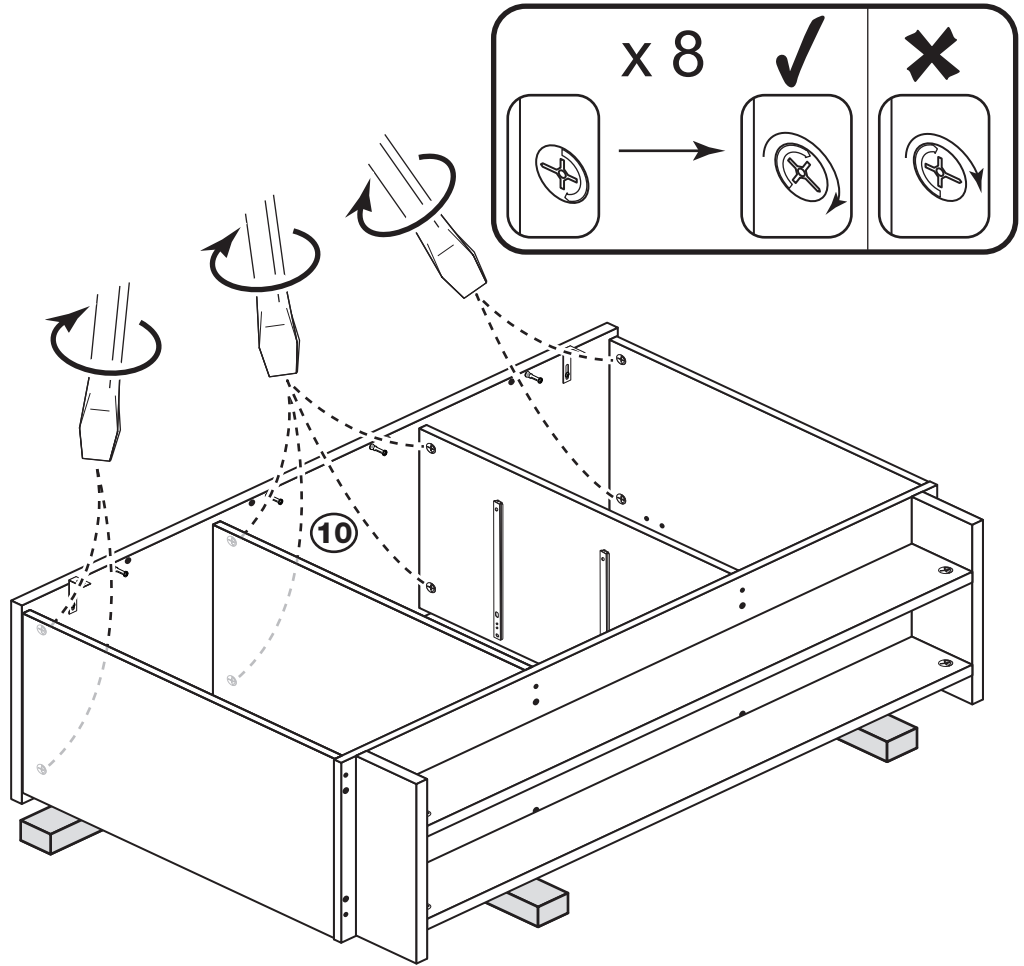

## Step 24

### Prepare the 2 Backs

Tap 2 Wooden Dowels into each Back.

Insert 2 Large Locking Cam Nuts into each Back.

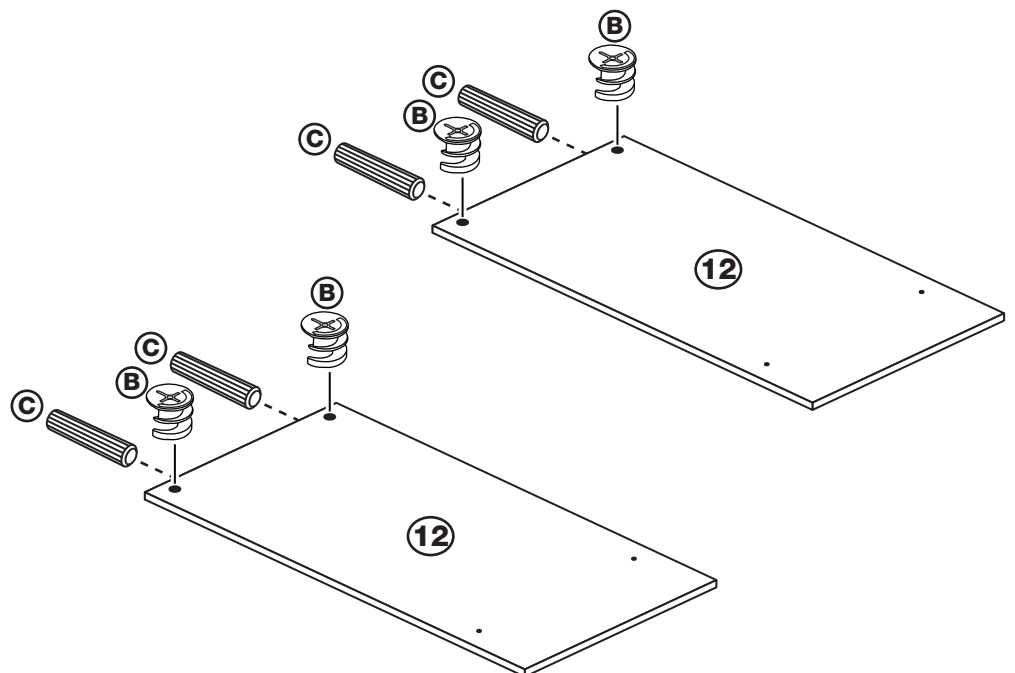

## Step 25

### Fit the 2 Backs

Push the 2 Backs onto the Top.

Use a screwdriver to tighten the 2 Large Locking Cam Nuts fitted to each Back.

Fix each Back to the back edge of the Base with two 45mm Screws.

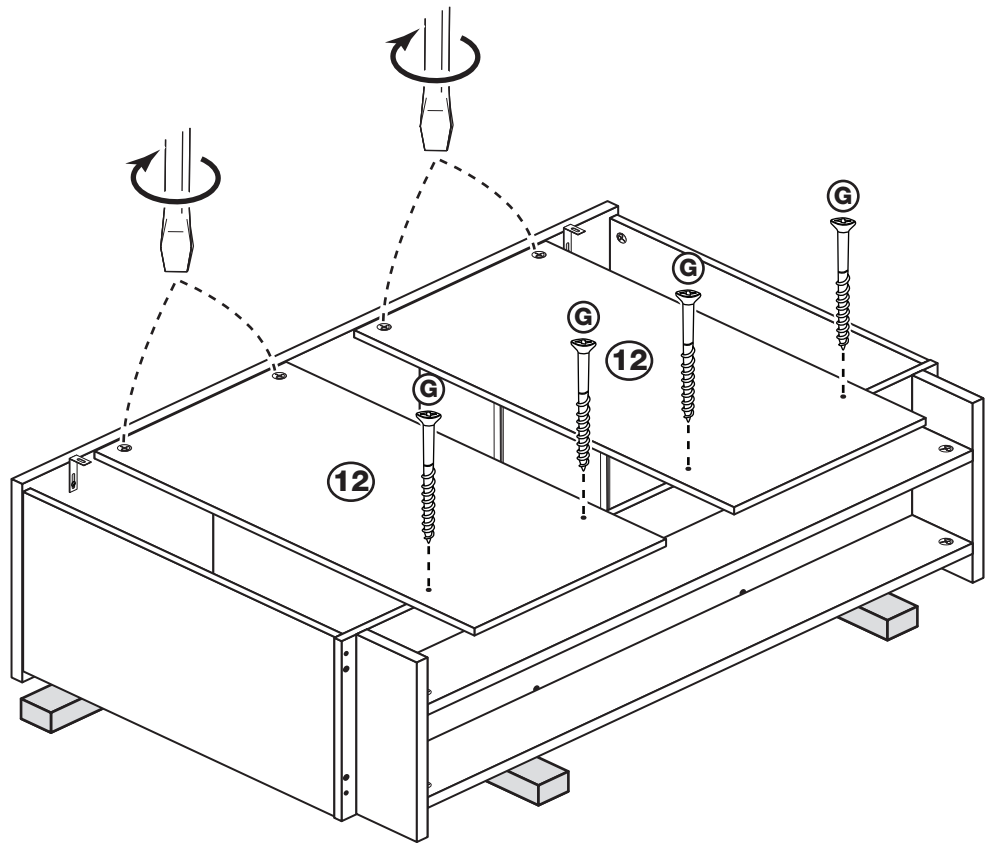

## Step 26

### Secure the unit to a wall

**a:** Before fitting the unit to a wall, use a spirit level to check the top of the unit is level, front-to-back and side-to-side in the 3 positions shown. Use suitable packing pieces (not supplied) to make the unit level.

To prevent possible overbalancing this unit must be secured to a suitable wall by fitting the Overbalance Protector Kit to a wall.

**b:** Push the unit up against the wall and slide the Brackets against the wall. Fit the 2nd Screws from the kit into the underside of the Top panel.

Mark the slot at the back of the Brackets for drilling into the wall.

Wall fixings are not supplied as they will need to suit the wall type.

Take care when drilling the wall that you do not drill into any pipes, wires etc. If in doubt, consult an expert.

**This unit must be fixed to a wall using the Overbalance Protector Kit provided**

**a:**

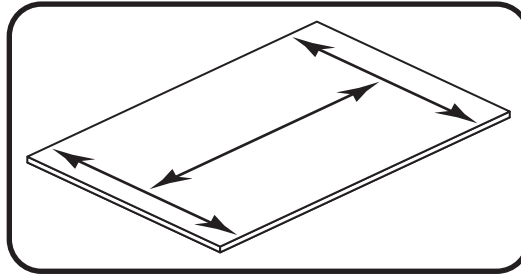

**b:**

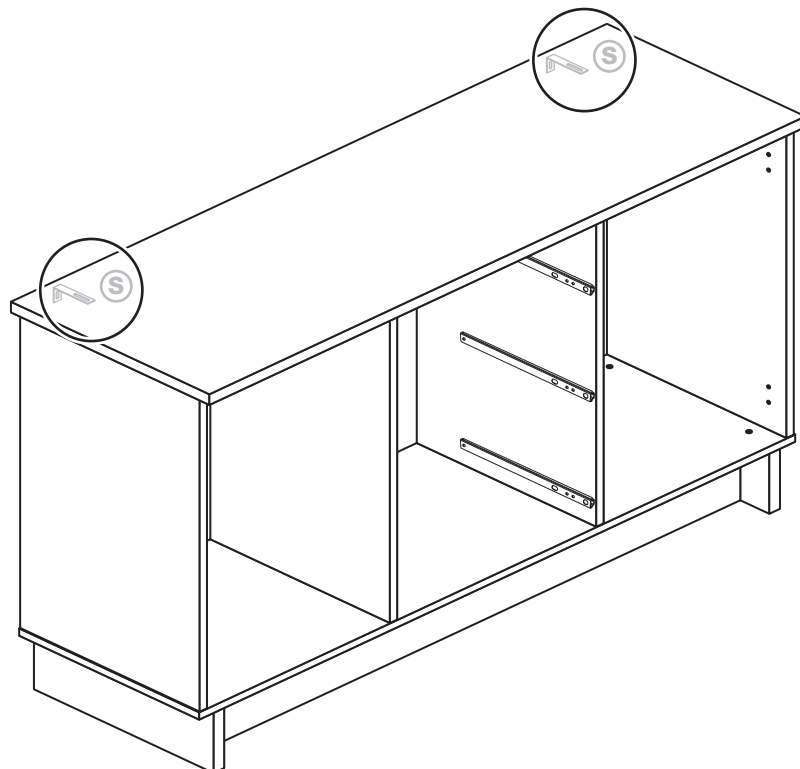
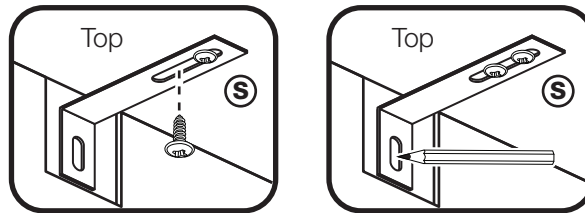



## Step 27

### Prepare the 2 Doors

Push fit 2 Hinges into each Door.

Secure each hinge with two 13mm Screws.

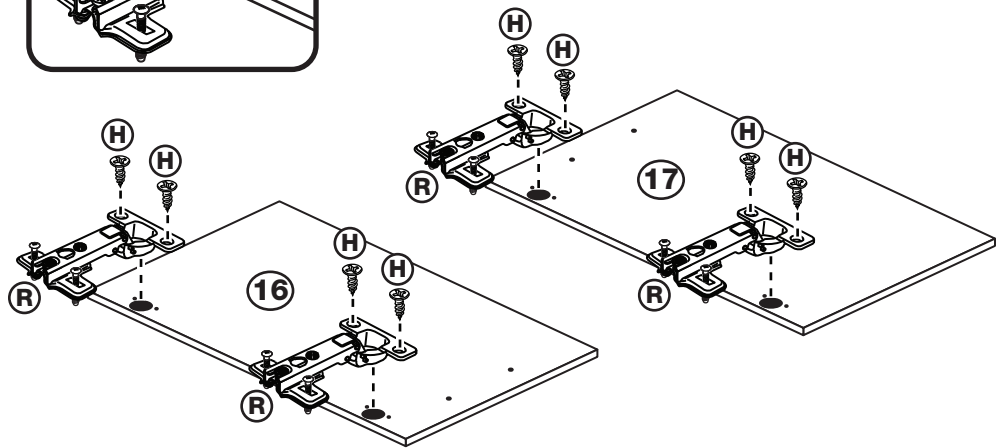
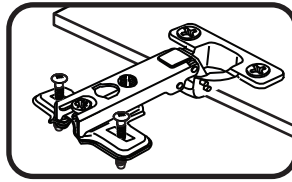

## Step 28

### Fit the Doors

Line up the 2 screws in the top Hinge with the 2 holes at the top of the Side and push them in.

Now push in the other Hinge.

When the Hinges have been pushed into place, tighten their 2 screws.

Press the screws into the holes in the panels

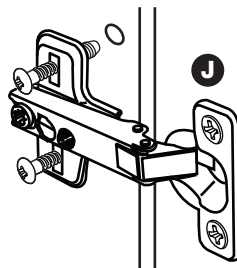

When the hinges have been pushed in, tighten up their screws

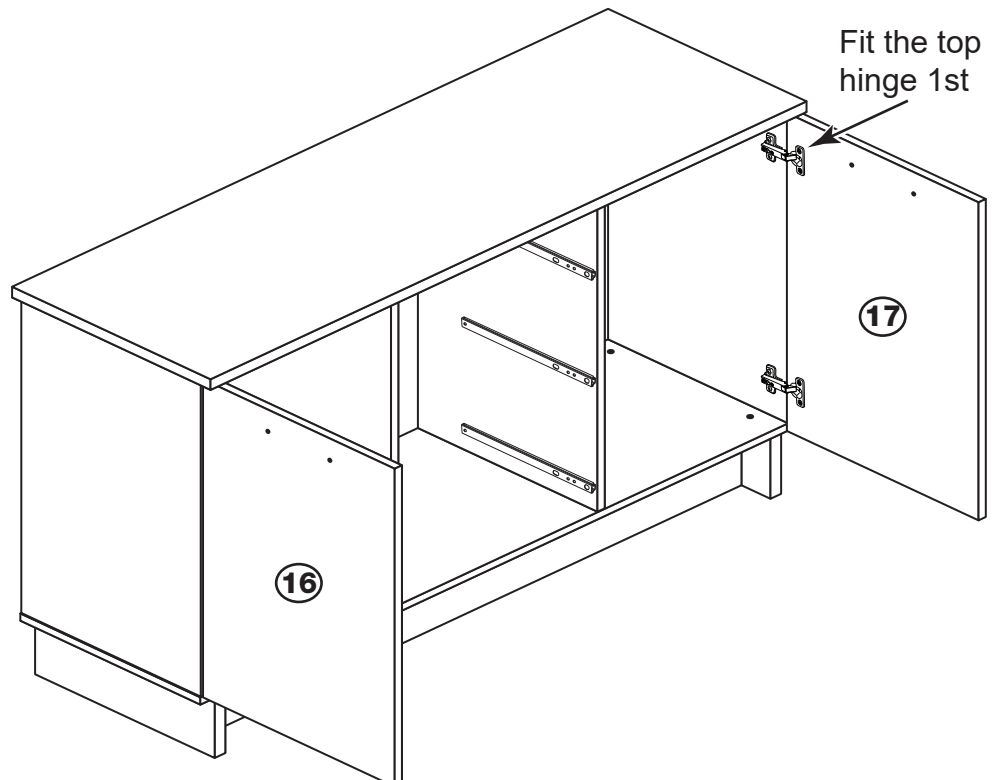
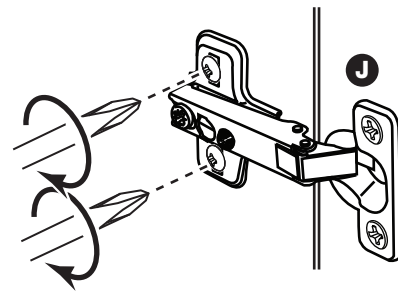

## Step 29

### Attach the Handles

Attach a Handle to each of the Doors using two 20mm Screws.

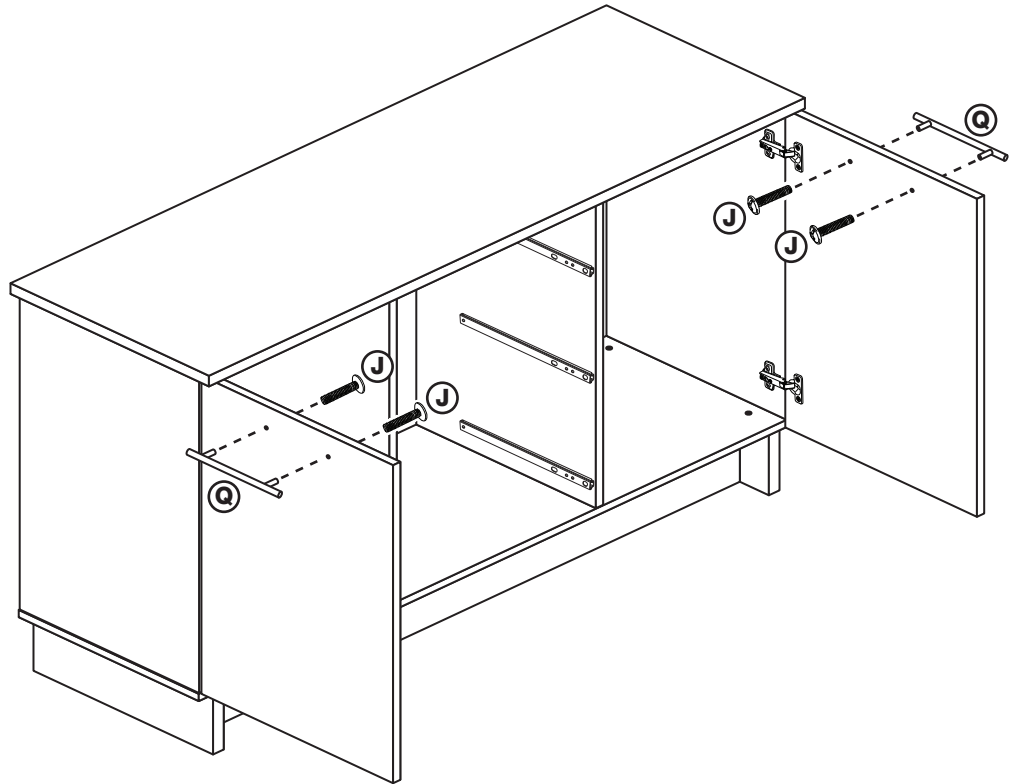

## Step 30

### Fit the Drawers

Starting with the bottom Drawer, slide both the Runners forward and locate the Drawer Sides between them, lining up their holes with the 2nd 'threaded' holes in the Runners.

Working from the inside of the Drawer, insert 2 9mm Screws through the Drawer Sides and out into the 2nd threaded hole in the Runner.

Note: Do not overtighten the Screws. If they catch on the Runner you may need to loosen them slightly.

The Runners could have sharp edges and we recommend that you position them using a Screwdriver

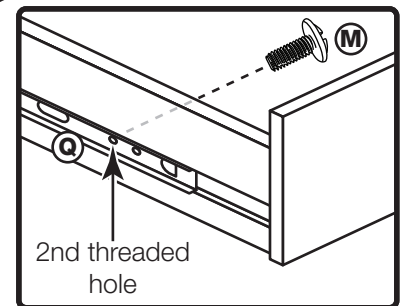
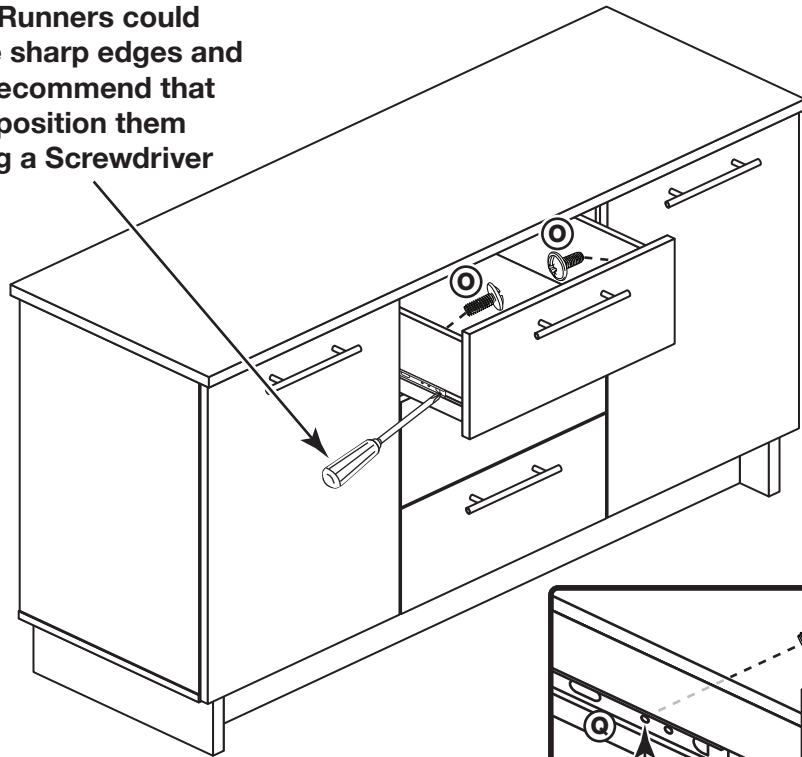

## Step 31

### Adjust the Doors if needed

**a:** Height adjustment. Loosen Screws A on Hinge Plates and move Door up or down as required. Retighten Screw A.

**b:** Forward and Back adjustment. Loosen Screw B on Hinge Plate and move Door in or out as required. Retighten Screw B.

**c:** Sideways adjustment. To move Door 'out' loosen Screw C. To move Door 'in' tighten Screw C.

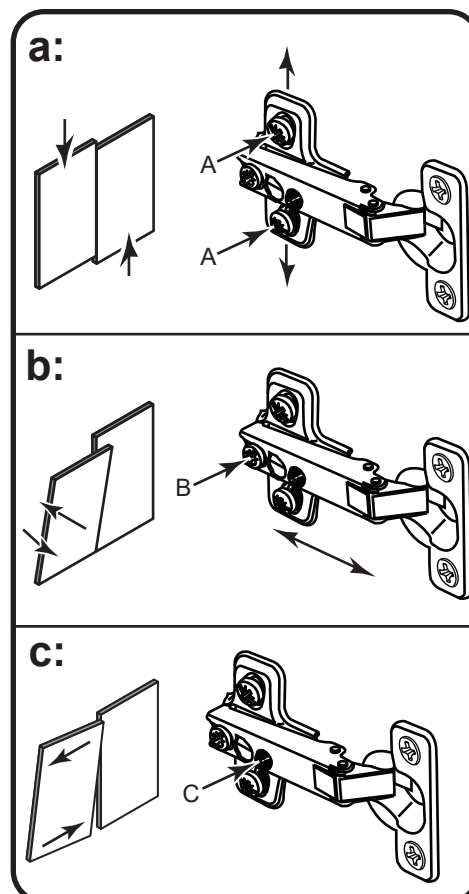

Step 32

Assembly is complete

