

AquaFill

Automatic Top Up System

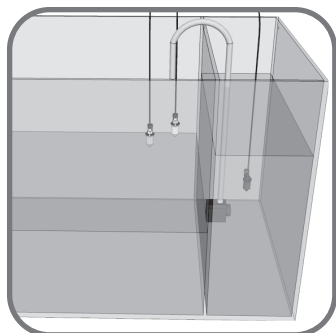

Instruction version: 11/07/2014

www.aquaone.com.au

Important Safeguards

To guard against injury, basic safety precautions should be observed, including the following:

1. Read and follow all safety instructions and important notices in these instructions as well as on the product itself.

2. This appliance can be used by children from 8 years and above and persons with reduced physical, sensory or mental capabilities or lack of experience and knowledge if they have been given supervision or instruction concerning use of the appliance in a safe way and understand the hazards involved. Children shall not play with the appliance. Cleaning and user maintenance shall not be made by children without supervision.

3. To avoid possible electric shocks, special care should be taken since water is employed in the use of aquarium equipment. For each of the following situations do not attempt repairs yourself. Return the appliance to an authorised service facility for service or discard the appliance.

a. If the appliance or any electrical component of the appliance (non-immersible equipment only) falls into the water or gets wet, do not reach for it. Unplug it and then retrieve it.

b. If the appliance shows any sign of abnormal water leakage, immediately unplug it from the power source.

c. Carefully examine the appliance after installation. It should not be plugged in if there is water on parts which are not intended to be wet.

4. Always unplug the appliance from the electrical outlet when not in use, before putting on or taking off parts, before any type of maintenance or cleaning.

5. Never yank the cable to pull it from the socket. Pull the plug carefully to disconnect.

6. Do not use the appliance for reasons other than the intended use. The use of attachments that are not recommended or sold by the manufacturer may cause the product to be unsafe. This is not recommended.

7. Do not install or store the appliance where it will be exposed to weather or temperatures below freezing.

8. Make sure any component mounted on a tank is securely installed before operating it.

9. Ensure input voltage is the same voltage as your local power supply.

10. If an extension cable is used it should have the proper rating. Care should be taken to arrange the cord so that it will not be tripped or pulled.

11. A G.F.C.I (Ground fault circuit interrupter) & surge protector is recommended for all electrical appliances.

12. Ensure your hands are dry when turning the power switch on/off and when inserting/removing the power cable from the socket. Remember to arrange a drip loop (see graphic).

13. If you are in any doubt about the electrical installation or safety of this product you must consult a qualified electrician.

14. The supply cord must not be repaired or replaced. If it is damaged, replace the entire pump unit.

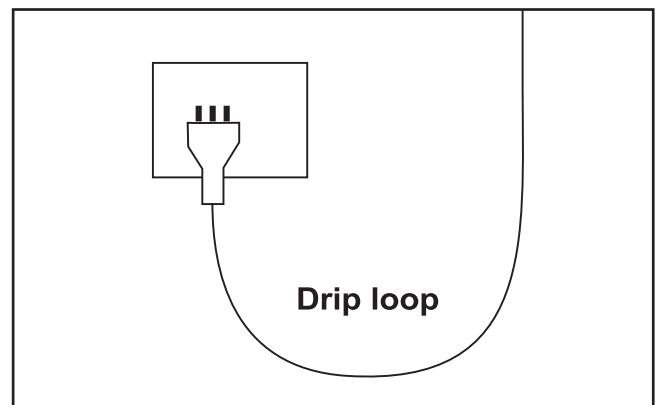

For Guarantee Conditions, please refer to the Guarantee form that is enclosed with this product.

All products are supplied with fitted plugs. This plug should not be tampered with in any way or removed. Removal or tampering with the plug invalidates our guarantee offered with this product.

For UK a 3 pin adaptor is supplied with the product and this must be used.

Before First Use / Preparation

Read and follow all the instructions, even if you feel you are familiar with the product and find a place to keep the instructions handy for future reference. Your attention is drawn particularly to the sections concerning **“IMPORTANT SAFEGUARDS”** and the **“GUARANTEE CONDITIONS”**. Please ensure you retain your original purchase receipt in the event that guarantee service is required.

Carefully unpack the filter making sure you keep all the packing material until all the parts of the product have been found and the product has been assembled.

This product is shipped to you in a factory sealed carton. Should the product malfunction in any way or if the unit is damaged and requires replacement, contact the retailer where the product was purchased for inspection.

Know Your Top Up System

AquaFill

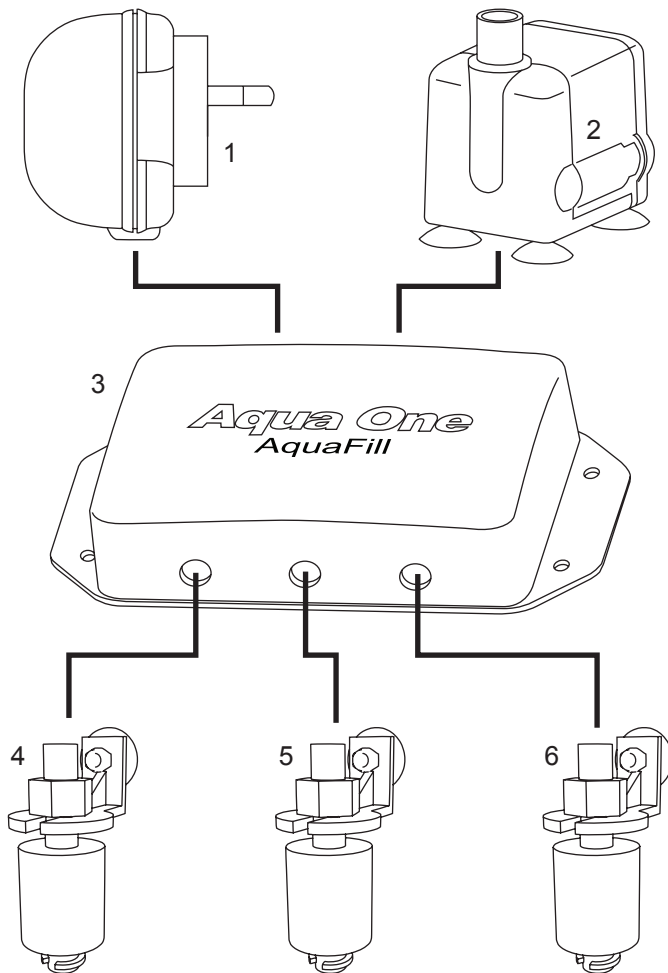

Set up/Parts

1. Power Supply
2. Pump
3. Control Box
4. Primary Float Switch
5. Secondary Float Switch
6. Reservoir Float Switch

Replacement Parts & Filter Media

AquaFill Impeller

351

Use Aqua One Genuine Spare Parts Only. See your local Aqua One Dealer and look for the number listed below for the spare part you require. Alternatively you will find these numbers on the silver label located on the product.

Installation

Follow the diagram below to set up the AquaFill system.

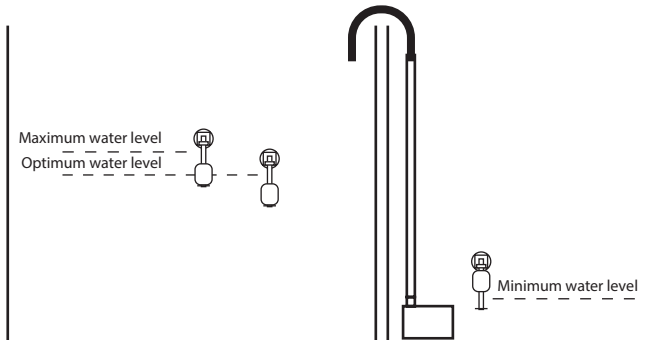

1. Find the point in the sump where the water level will fluctuate. This is usually the section that contains the return pump.

2. Decide on the water level you want to maintain in this section of the sump. Ensure it is high enough that the pump will not suck air while operating but low enough that the sump will not overflow if the return pump is switched off or loses power.

3. Attach the primary float switch to the side or rear of the sump at the optimum operating water level. Use the supplied suction cups to hold the cables in place above the float switches.

4. Attach the secondary float switch at the same level or up to 10cm higher than the primary float switch. This is the level that the sump will be filled to if the primary float switch sticks "on". Ensure the level of the secondary float switch is also below the point at which the sump would overflow if the return pump lost power.

5. Attach the reservoir float switch inside the top-up reservoir at the point that you do not want the pump operating below. This will prevent the pump from operating when the reservoir is empty which could cause damage to the pump due to overheating. Generally this level will be around 5-8cm from the bottom of the reservoir.

6. Place the pump inside the reservoir and attach the supplied 9mm hose to feed the water from the reservoir to the sump. Check the hose for kinks which will significantly reduce or stop flow from the pump. Attach the other end of the hose to the supplied U-pipe. Hang the U-pipe from the side of the sump. Ensure the outlet is above the maximum water level for the sump to ensure water does not siphon back to the reservoir when the pump stops.

7. Connect the float switches to the control box ensuring each is connected to the appropriate socket as marked on the control box.

8. Connect the pump to the control box using the socket labelled "pump". Connect the supplied power supply to the socket labelled "power in" using the supplied male-male power cable.

9. Fill the reservoir with water to be used to top the aquarium up. It is recommended to use RO or RO/DI water but dechlorinated tap water can also be used. Never top an aquarium up with salt water as the salts do not evaporate out and saline top-up water will increase the salinity of the aquarium.

10. Place a lid on the top-up reservoir to avoid evaporation.

NOTE: Ensure the correct float switches are used in the correct location. The **primary** and **secondary** float switches operate as shown below:

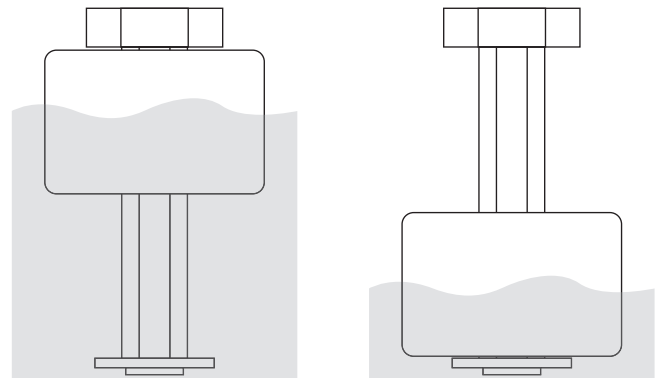

High water level: off

Low water level: on

The **reservoir** float switch operates as shown below:

High water level: on

Low water level: off

NOTE: The primary and secondary float switches can be identified by having a BLACK plug while the reservoir float switch has a WHITE plug.

Operation

When operating, the AquaFill pump will switch on when the water level falls below BOTH primary and secondary float switches.

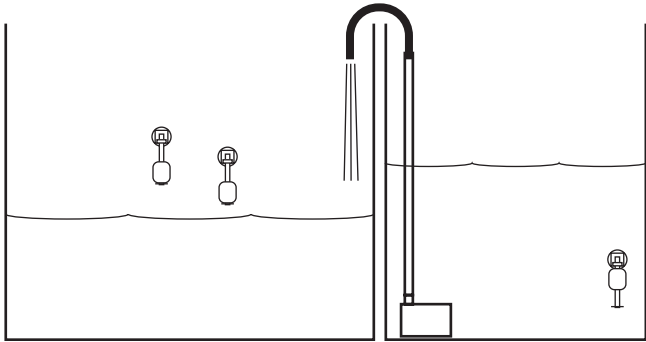

The pump will continue to run until ONE of the primary OR secondary float switches are submerged.

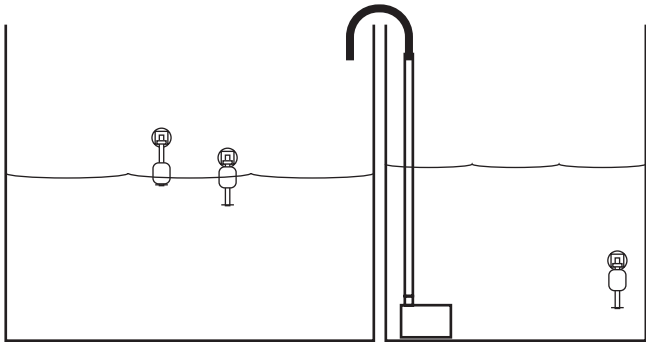

However, if the water level of the reservoir drops below the reservoir float switch, the pump will stop to prevent the pump from running dry and causing damage to the pump.

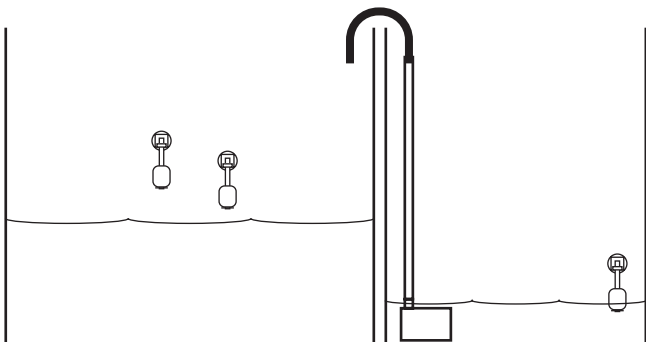

Pump Maintenance

Clean the impeller at least once a month.

1. Switch off the power to the top-up unit.
2. Remove the power head from the reservoir and take it to the sink.
3. Grasp the motor with one hand and pre filter/mounting bracket with the other and gently pull apart.
4. Remove the impeller cover to gain access to the impeller.
5. Pull impeller from the motor and rinse properly. Use an Aqua One double ended pipe brush (sold separately) to clean the impeller, the impeller well and the outlet.
6. Put the pump back together and return to the reservoir. Ensure your hand is not wet, plug in at the power supply and turn on.

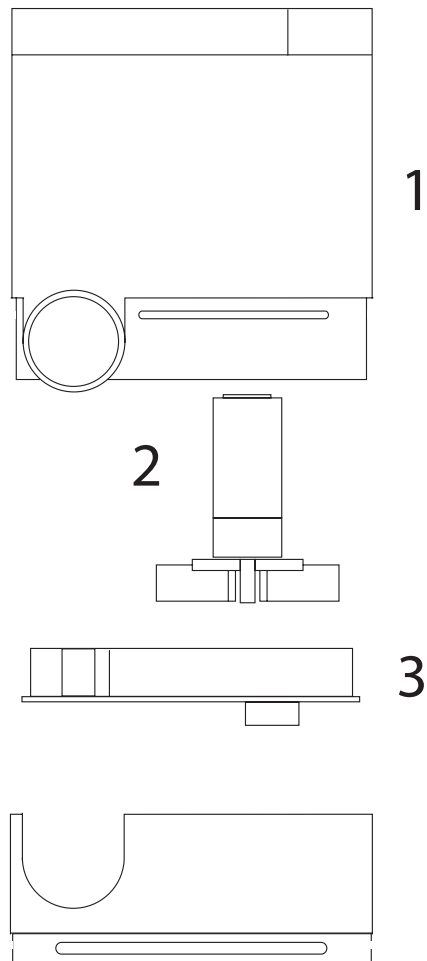

1. Motor
2. Impeller
3. Impeller cover
4. Inlet Cover

Trouble Shooting

Specifications

SUMP WATER LEVEL IS LOW AND NOT FILLING

1. Ensure reservoir is full.
2. Ensure all power connections are securely plugged in and are connected to the correct sockets on the power box.
3. Check that float switches have not “stuck” in the off position (high for primary and secondary, low for reservoir). Primary and secondary float switches should be rinsed in fresh water occasionally to prevent salt buildup which can cause them to stick.
4. Check the pump is in good working order. The pump can be plugged directly into the power supply to check.
5. Check that the hose connecting the pump to the sump is not kinked or blocked.

SUMP IS FILLING PAST BOTH IN-SUMP FLOAT SWITCHES

1. Check that all float switches are connected to the correct sockets on the power box.
2. Check that the primary and secondary float switches have not “stuck” in the on position (low position). Rinse the float switches regularly in fresh water to prevent salt buildup which can cause them to stick.

Model: AquaFill

Maximum Flow Rate: 200L/hr

Max Head Height: 0.5m

Power Requirements: 12V AC

Power Consumption: 3.5W

Suitable: Cold water, Tropical, Marine

Correct Disposal of this product



This marking indicates that this product should not be disposed with other household waste throughout the EU. To prevent harm to the environment or human health from uncontrolled waste disposal, recycle it responsibly to promote the sustainable reuse of material resources. To return your used device, please use the return and collection systems or contact the retailer where the product was purchased. They can take this product for environmental safe recycling.

Aqua One Manufacturers Guarantee 1 + 1 Year

The additional 1 Year **Extended Guarantee** applies when you REGISTER online with Aqua One. Register your Extended Guarantee at www.aquaone.com.au

About this Guarantee

The Manufacturer or Distributor, of Aqua One goods, is collectively known herein as "Aqua One". Please refer to contact details for Aqua One below or on the applicable Aqua One website. Any product that is covered by its own Guarantee (as enclosed with the product) is subject to the conditions of that Guarantee.

Australian Guarantee

Important note: This guarantee applies in addition to the guarantees, rights and remedies conferred by the Australian Consumer Law and other applicable Commonwealth, State and Territory legislation. The guarantee does not exclude, affect or limit those guarantees, rights or remedies, except to the extent that their application may lawfully be excluded or limited.

In particular, our goods come with guarantees that cannot be excluded under the Australian Consumer Law. You are entitled to a replacement or refund for a major failure and for compensation for any other reasonably foreseeable loss or damage. You are also entitled to have the goods repaired or replaced if the goods fail to be of acceptable quality and the failure does not amount to a major failure.

International Guarantee

The benefits given to the purchaser, under Guarantee, are in addition to all other statutory rights and remedies which the purchaser has in respect of goods under legislation in the applicable country of purchase. This Guarantee shall not affect any such rights and should be read subject to such legislation.

1.0. Terms and Conditions of Guarantee.

- 1.1. Aqua One warrants to the purchaser, for 1 Year from date of original purchase, to repair or replace goods where fault is found due to defective materials or faulty workmanship and where goods do not operate in accordance with the instructions.
- 1.2. All claims for repair or replacement must be made at place of purchase.
- 1.3. The original and dated Proof of Purchase (receipt) must be supplied with all goods claims. Please also provide this Guarantee where possible.
- 1.4. The Guarantee covers the Aquarium against gluing breakdown resulting in leakage.
- 1.5. All goods subject to claim under Guarantee should be prepared for transportation in the original packaging or other comparable packaging which offers the same degree of protection.
- 1.6. Where goods are repaired or replaced under Guarantee, these goods are Guaranteed for the remainder of either the original Guarantee or Extended Guarantee period.
- 1.7. Where claims on inspection reveal goods are in normal working order, Aqua One will request reimbursement of all reasonable costs incurred.

2.0. Other Terms and Conditions – Extended Guarantee

- 2.1. The Extended Guarantee period is for an additional 1 Year and commences on expiration of the standard guarantee period.
- 2.2. Application for Extended Guarantee is FREE of any registration cost to the purchaser on completion of the Extended Guarantee questionnaire which is found on the applicable Aqua One website (refer below).
- 2.3. Upon receipt and acceptance of the questionnaire, Aqua One will forward (by way of email) a Certificate of Extended Guarantee to the purchaser.
- 2.4. For more information on how we collect, hold, use and disclose personal information provided to us, please refer to our Privacy Statement on the Aqua One websites or write to our Privacy Officer, in your country of purchase.
- 2.5. Where Aqua One determines goods are being used in a manner contrary to the instructions, specifications or this Guarantee, Aqua One reserves the right to terminate Extended Guarantee for such goods and will provide written notice to the purchaser.

3.0. Exclusions and Limitations

Where permitted by local law, the following exclusions and limitations apply in regard to Guarantee:

- 3.1. Glass breakage, for whatever reason caused after Aquarium purchase.
 - 3.2. Goods claims where fault is due to, but not limited by a) misuse b) neglect c) abuse d) fire or flood e) normal wear and tear f) accidental breakage g) Acts of God h) mains voltage fluctuation or supply problems i) connection to any voltage other than what is stated on the rating plate j) modification or tampering to electrical cord or plug, k) vermin, insects or foreign object l) liquid spillage or submersion of goods not designed to sustain such use or duress.
 - 3.3. Where inspections reveal goods are in normal working order including where noise or vibration is consistent with normal goods operation.
 - 3.4. Attempted repairs or modifications by unauthorised persons, including but not limited to the drilling of holes in the aquarium glass by unauthorised persons.
 - 3.5. Where the goods factory rating plate has been removed, altered, damaged or is rendered illegible.
 - 3.6. Where goods are not installed, operated or maintained in accordance with Aqua One's goods instructions, specifications or this Guarantee.
 - 3.7. Replacement or repair of worn consumables or replacement of lost goods, parts or components.
 - 3.8. Costs associated with goods transportation, removal, installation, postage or cost of insurance.
 - 3.9. Any damage incurred whilst installing, transporting or moving the goods.
 - 3.10. Subject to certain local statutory rights and obligations to the contrary, and this guarantee shall not affect those rights or obligations, where, to the full extent permitted by law: 1. all express and implied warranties and conditions under statute or general law, are expressly excluded and Aqua One, where permitted, will limit liability as follows and at Aqua One's option to: in regard to goods either a) the replacement of goods or supply of equivalent goods b) the repair of goods or the cost of replacing the goods or of acquiring equivalent goods OR in regard to services either c) the re-supply of services d) the cost to re-supply services.
2. Aqua One will not be liable for any loss or damage, including consequential loss or damage either directly or indirectly, or for any incidental expenses, of any kind, and in any way whatsoever.

(1) consumables include items such as filter media/cartridges, impellers and shafts, light tubes, lamps, bulbs and starters.

Aqua One may be contacted in:
Australia
Kong's (Aust.) Pty. Limited
PO Box 863, Ingleburn
1890 NSW Australia
www.aquaone.com.au

Hong Kong
Kong's Aquarium Supplies Co., Ltd
No 31, 3/F Thriving Industrial Centre
26-38 Sha Tsui Road, Tsuen Wan,
Hong Kong
www.aquaone.co.hk

New Zealand
Kong's (NZ) Limited
PO Box 15 - 183, Tauranga
3015 New Zealand
www.aquaone.co.nz

United Kingdom
Kong's (UK) Limited,
C/O Aqua Pacific UK Ltd.
PO Box 268
Romsey Hampshire, SO51 0WW
United Kingdom
www.aquaone.co.uk



Manufactured in China.
Designed in Australia by Aqua One.
Aqua One and *Aqua One Inspiring
Excellence in Fish Care!* are registered
trademarks or trademarks.

www.aquaone.com.au