

LifeStyle Series Aquariums

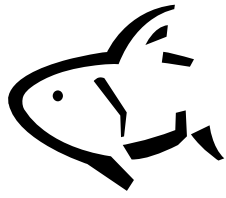

Aqua One®

Inspiring Excellence in Fish Care!

1+1
YEAR
GUARANTEE



Instruction version: 29/08/2016

www.aquaone.com.au

Important Safeguards

To guard against injury, basic safety precautions should be observed, including the following:

1. Read and follow all safety instructions and important notices in these instructions as well as on the product itself.

2. This appliance is not intended for use by children or infirm persons without supervision. Young children should be supervised to ensure that they do not play with the appliance.

3. To avoid possible electric shocks, special care should be taken since water is employed in the use of aquarium equipment. For each of the following situations do not attempt repairs yourself. Return the appliance to an authorised service facility for service or discard the appliance.

a. If the appliance or any electrical component of the appliance (non-immersible equipment only) falls into the water or gets wet, do not reach for it. Unplug it and then retrieve it.

b. If the appliance shows any sign of abnormal water leakage, immediately unplug it from the power source.

c. Carefully examine the appliance after installation. It should not be plugged in if there is water on parts which are not intended to be wet.

d. Do not operate the appliance if it has a damaged cord or plug, or if it is malfunctioning, or dropped or damaged in any manner.

4. A “drip loop” (see graphic) should be arranged for each cable connecting an aquarium to a power supply. The drip loop is the part of the cable below the level of the power supply. It prevents water travelling down the cable and coming into contact with the power supply. If the plug or the socket does get wet, do not unplug the appliance. Disconnect the fuse or circuit breaker that supplies the power to the appliance, then unplug and examine for presence of water in the socket.

5. Always unplug the appliance from the electrical outlet when not in use, before putting on or taking off parts, before any type of maintenance or cleaning.

6. Never yank the cable to pull it from the socket. Pull the plug carefully to disconnect.

7. Do not use the appliance for reasons other than the intended use. The use of attachments that are not recommended or sold by the manufacturer may cause the product to be unsafe. This is not recommended.

8. For an aquarium, be mindful when selecting a location, in particular a location near general household electrical equipment. Should the aquarium leak for any reason, water coming into contact with electrical equipment not intended to be wet may damage or destroy the equipment.

Also consider the location based on the maintenance requirements as water may be accidentally spilled during maintenance.

9. Do not install or store the appliance where it will be exposed to weather or temperatures below freezing.

10. Make sure any component mounted on a tank is securely installed before operating it.

11. Ensure input voltage is the same voltage as your local power supply.

12. If an extension cable is used it should have the proper rating. Care should be taken to arrange the cord so that it will not be tripped or pulled.

13. A G.F.C.I (Ground fault circuit interrupter) & surge protector is recommended for all electrical appliances.

14. Ensure your hands are dry when turning the power switch on/off and when inserting/removing the power cable from the socket.

15. If you are in any doubt about the electrical installation or safety of this product you must consult a qualified electrician.

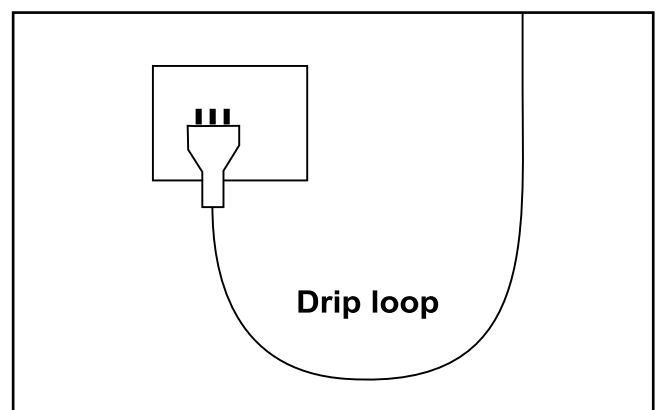

For Guarantee Conditions, please refer to the Guarantee form that is enclosed with this product.

All products are supplied with fitted plugs. This plug should not be tampered with in any way or removed. Removal or tampering with the plug invalidates our guarantee offered with this product.

For UK a 3 pin adaptor is supplied with the product and this must be used.

Before First Use / Preparation

Read and follow all the instructions, even if you feel you are familiar with the product and find a place to keep the instructions handy for future reference. Your attention is drawn particularly to the sections concerning **“IMPORTANT SAFEGUARDS”** and the **“GUARANTEE CONDITIONS”**. Please ensure you retain your original purchase receipt in the event that guarantee service is required.

Carefully unpack the aquarium making sure you keep all the packing material until all the parts of the product have been found and the product has been assembled.

This product is shipped to you in a factory sealed carton. Should the product malfunction in any way or if the unit is damaged and requires replacement, contact the retailer where the product was purchased for inspection.

Know Your Tank

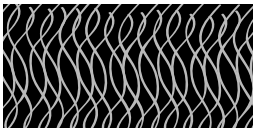

Sponge

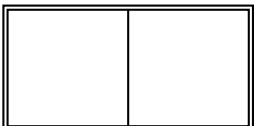

Carbon Cartridge

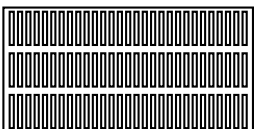

Filter Grid

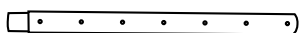

Spray Bar



End Cap

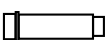

Intake Pipe



Intake Strainer



Elbow Adapter



Rubber Mount

Replacement Parts & Filter Media

Use Aqua One Genuine Spare Parts Only. See your local Aqua One Dealer and look for the number listed below for the spare part you require. Alternatively you will find these numbers on the silver label located on the product.

LifeStyle 21	Impeller Set	164I
LifeStyle 21	Carbon Cartridge	1C
LifeStyle 21	Sponge Pad	164S
LifeStyle 29	Impeller Set	165I
LifeStyle 29	Carbon Cartridge	1C
LifeStyle 29	Sponge Pad	164S
LifeStyle 52	Impeller Set	166I
LifeStyle 52	Carbon Cartridge	2C
LifeStyle 52	Sponge Pad	2S
LifeStyle 76	Impeller Set	166I
LifeStyle 76	Carbon Cartridge	167C
LifeStyle 76	Sponge Pad	167S
LifeStyle 127	Impeller Set	168I
LifeStyle 127	Carbon Cartridge	168C
LifeStyle 127	Sponge Pad	168S

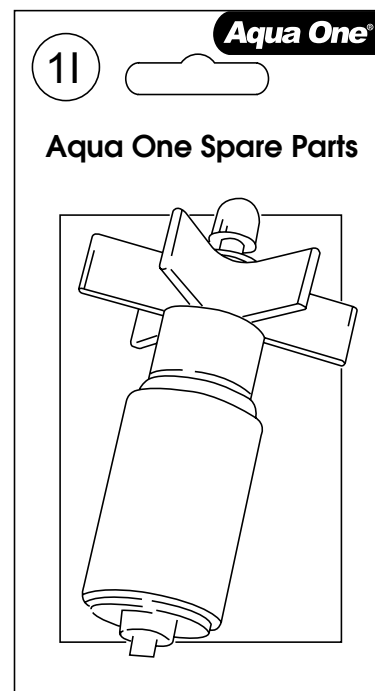

Set Up Instructions

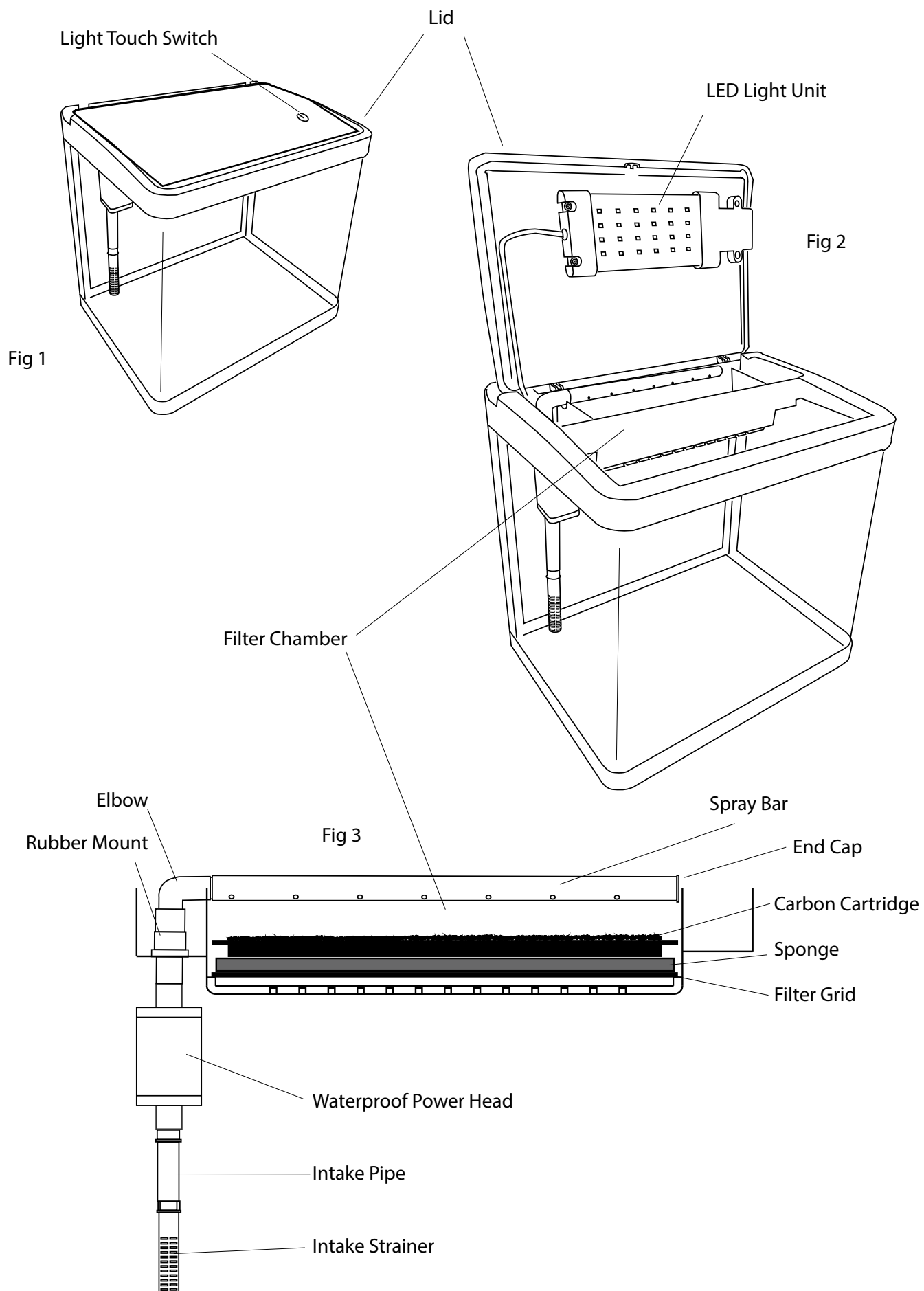

Set Up Instructions

1. Wash your hands and arms. It is very important to remove dirt, moisturizer and other impurities. Do this whenever you work on the aquarium.

2. Wash the following **DO NOT WASH IN SOAP OR DETERGENT.**

Filter Sponge, Carbon Cartridge, Filter Grid, Spray Bar, Intake Pipe, Strainer, Elbow, Glass Tank (Inside).

3. Connect the Intake Pipe and Strainer together.

4. Mount the Power Head on the filter. To do so, fit the Rubber Mount to the Power Head and slide the mount onto the bracket on the filter body.

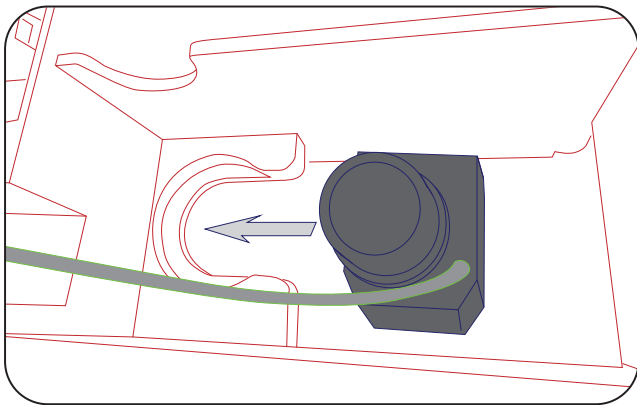

5. Attach the intake pipe to the bottom of the Power Head. (Fig 3)

6. Place the filter grid in the bottom of the filter unit. (Fig 3)

7. Place the black filter sponge on top of the Filter Grid. (Fig 3)

8. Place the carbon cartridge on top of the black filter sponges with the wool facing upwards. (Fig 3)

9. Connect the elbow in to the Rubber Mount at the top of the power head. (Fig 3)

10. Then connect the spray bar to the other end of the elbow. Make sure the holes of the spray bar are pointing down and that the end of the spray bar has the cap fitted. (Fig 3)

11. Consider where you are going to place the aquarium. Keep it away from direct light or areas with large temperature fluctuations.

12. Place the aquarium on a flat level surface strong enough to support its weight. We recommend a genuine Aqua One Aquarium Cabinet (Sold separately) rather than general household furniture.

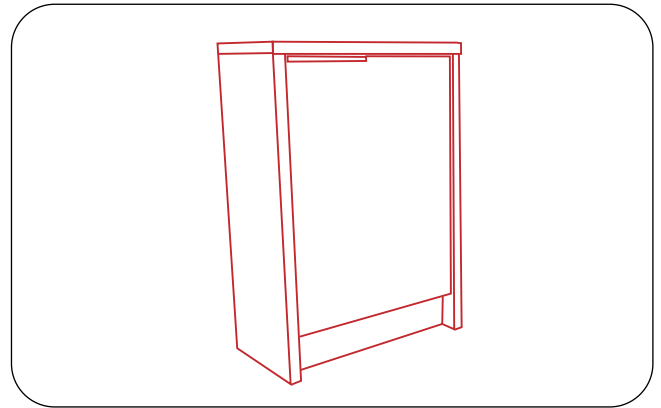

13. Wash aquarium gravel. Place a portion of gravel into a bucket, run water through & churn it over with your hand until the water running out of the bucket is clear. It is important to wash the gravel thoroughly. Repeat this process several times until all the gravel has been washed.

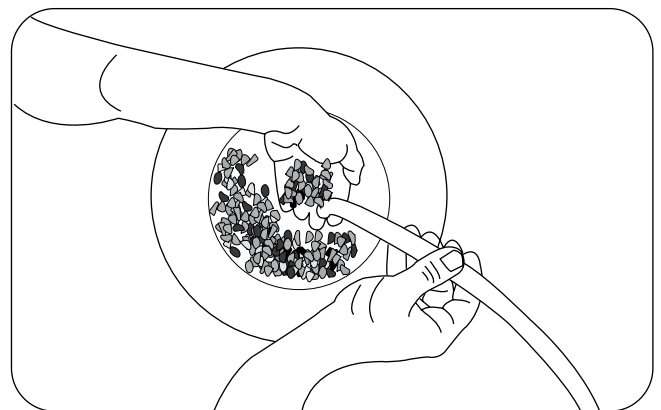

14. Place washed gravel over the base of the Aquarium.

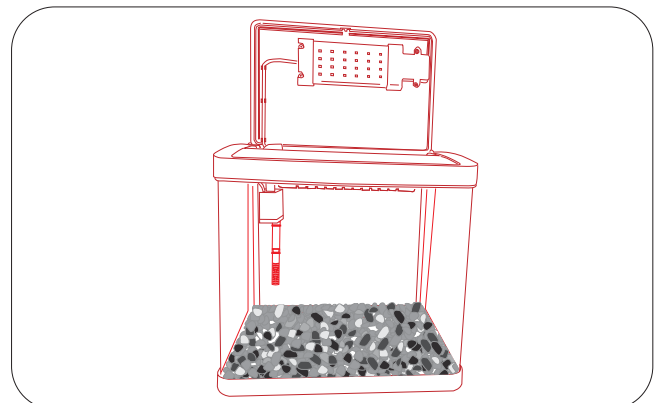

Set Up Instructions

15. At this stage place plastic plants, decorations and heater (See Tips) in to the tank.

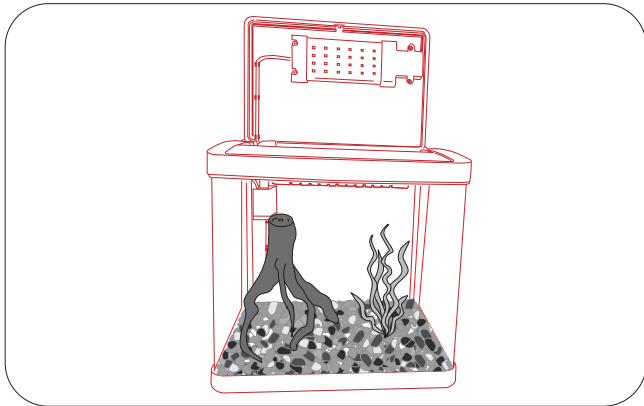

16. Fill the aquarium with tap water to within 1 cm of the top frame.

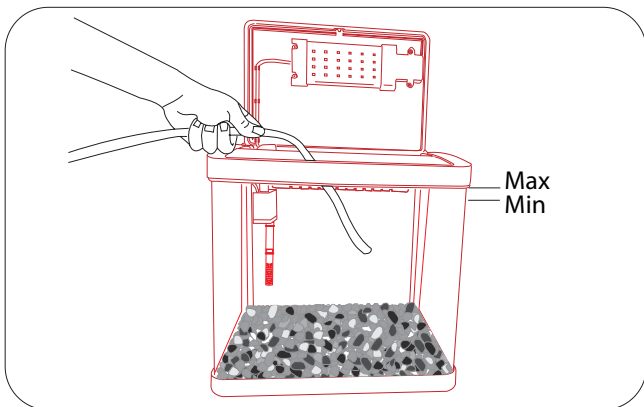

17. Use Aqua One quality Water Conditioner (Sold separately) to remove harmful chemicals chlorine and heavy metals from tap water

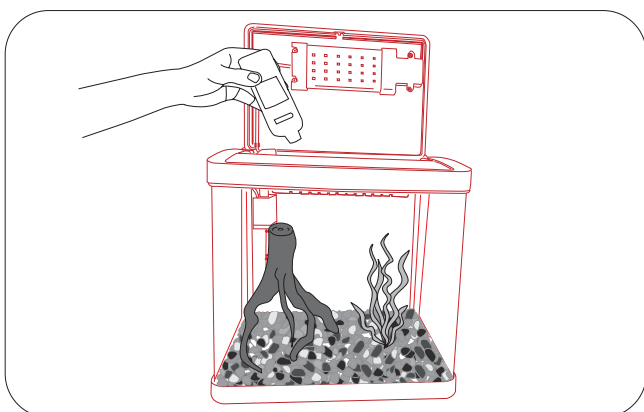

18. Plug in the filter and check that water is flowing correctly.

19. Close the lid and ensure that the light works.

20. Test and adjust pH levels.

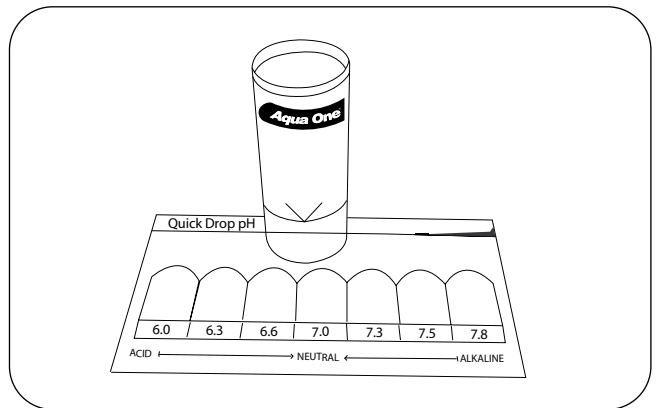

21. Allow the aquarium to stand for 5-7 days before introducing a few hardy fish.

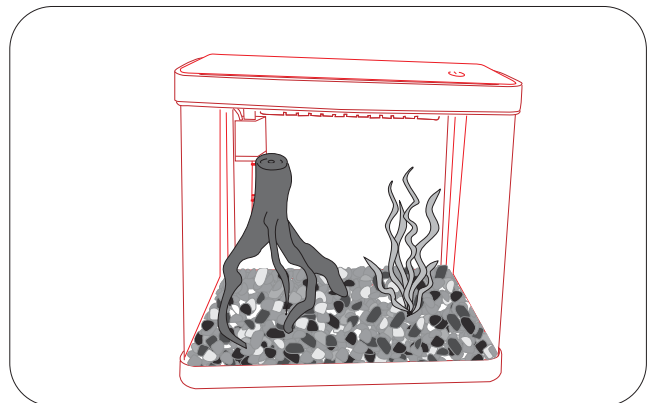

22. Seek advice from your retailer for correct fish numbers and species compatibility.

TIPS

An Aqua One heater and Thermometer is required if you are setting up a tropical aquarium. Refer to heater instructions for correct set up and positioning.

Chlorine and other heavy metals will harm your fish. Aqua One water conditioner will remove these impurities and create a safe environment for your fish.

These products are available separately from your local Aqua One retailer.

Know your light

The touch operated light switch is marked with the symbol shown. It has three settings.



The first touch will turn on the blue LEDs.

The second will turn on all of the LEDs.

The third will turn the light off.

Tank Maintenance

DAILY Feed your fish as per instructions on your fish food container.

Check fish ensure they are eating, breathing and swimming normally.

Check temperature.

Count fish numbers.

Ensure all filters, pumps, heaters and other aquarium accessories are functioning correctly.

WEEKLY Test and adjust pH levels if needed

Use Aqua One quality pH test kit, available from your local Aqua One retailer. pH is a measure of how acidic or alkaline the water is. It is measured on a scale of 0-14 in which 7 is neutral, less than 7 is acidic and more than 7 is alkaline.

Some species require specific pH levels please seek advice from your aquarium specialist.

FORTNIGHTLY 25% Water Change

What you will need: A bucket, gravel cleaner, towel, water conditioner, filter supplement and clean hands. All items are available from your local Aqua One retailer.

1. Unplug all equipment.
2. Open the Aquarium Lid.
3. The fish and plants do not need to be removed when doing any maintenance.
4. Place the towel on the floor in front of the aquarium to guard from water spillage.
5. Use an Aqua One 4 in 1 algae scraper (Sold separately) and gently scrape away any algae growing on the glass or filter pipes.
6. Using an Aqua One gravel cleaner* (Sold separately) empty approximately 25% of the aquarium water into the bucket. Take note of how much water is emptied.
7. Fill the bucket up with the same amount of water that was removed from the aquarium.
8. Treat the tap water with Aqua One water conditioner (Sold separately) as per the instructions on the bottle.
9. Let the bucket sit for 10 minutes.
10. Fill the aquarium up slowly to the level indicated (see page 6)
11. Turn the power head back on and ensure that water is flowing out of the spray bar.
12. Test and adjust pH levels.
13. Add a filter supplement such as Aqua One Bio Start 14. Replace the light unit.
14. Close lid and turn light on.

* Refer to the instructions on the back of your gravel cleaner to ensure correct use.

Filter Maintenance

WEEKLY

1. Unplug all equipment.
2. Open the lid.
3. Remove the elbow and spray bar unit from the top of the power head.
4. Remove the carbon cartridge and black filter sponge from the filter unit.
5. Empty a small amount of water from the aquarium into a bucket.
6. Rinse the black filter sponge in the bucket. Discard the used water; do not add it back into the aquarium.
7. Rinse the carbon cartridge out under the tap, rinse thoroughly.
8. Reinsert the black filter sponge and carbon cartridge.
9. Then connect the elbow and spray bar unit back onto the outlet at the top of the power head. Make sure the holes of the spray bar are pointing down onto the carbon cartridge and that the end of the spray bar has the cap fitted.
10. Ensure the aquarium is full. (Refer to page 6.)
11. Turn the power head back on and ensure that water is flowing out of the spray bar.
12. Replace the lid on the filter unit.
13. Add a filter supplement such as Aqua One Bio Starter.

The carbon filter cartridge should be replaced every 6 - 8 weeks for optimum filter performance.

MONTHLY

1. Turn the power off. Unplug both power leads.
2. Open lid.

3. Disconnect spray bar and elbow and clean with an Aqua One double ended pipe brush.
4. Remove the power head from the filter unit.
5. Pull impeller cover off bottom of power head, this will uncover the impeller.
6. Grasp the impeller blades and remove from the impeller chamber.
7. Use an Aqua One double ended pipe brush to clean impeller and inside of impeller chamber.
8. Also run a pipe brush through the outlet at the top of the power head.
9. Clean the intake pipe and strainer thoroughly.
10. Reconnect all parts and place filter unit back onto the aquarium.
11. Ensure the power lead is not wet and plug it back in.
12. Turn the power back on and check that water is flowing through the spray bar.
13. Close lid.

Powerhead Diagram

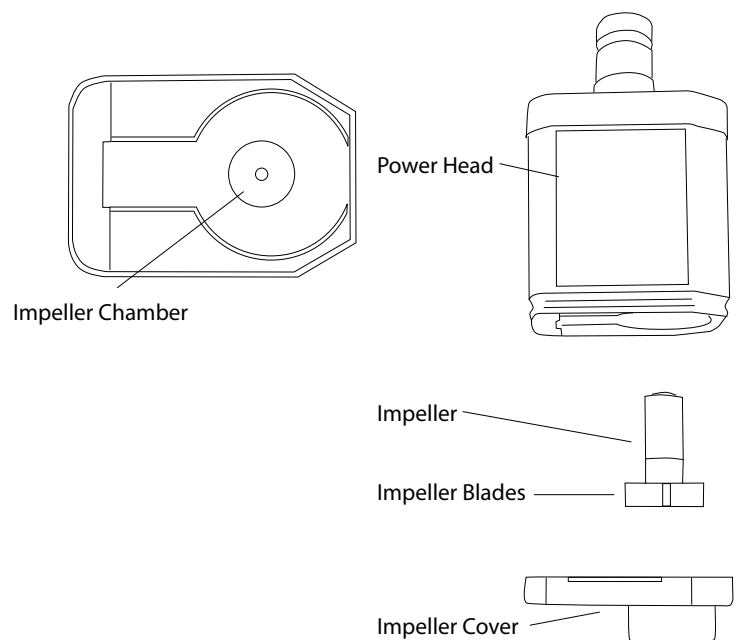

Hints & Tips For Best Results

Introduction of Fish

Note: This is only a guide! You should seek professional advice from your aquarium specialist at the time of purchase.

DO NOT ADD ALL FISH AT ONCE!

Build stock levels slowly over time. Allow at least one week between additions of fish. Add a filter supplement to help the biological system cope with the additional waste.

Do not over crowd. Remember all fish will grow, so allow them adequate space.

LIVE PLANTS

Once the water conditions and pH levels have been corrected, live plants can be added to the aquarium. Remember to empty some water from the aquarium before adding anything to it.

REMEMBER LIVE PLANTS NEED TO BE FED!

An aquarium safe plant fertiliser should be used.

LIGHTING

It is recommended that the light is turned completely off for at least 8 hours per day to allow the fish a proper night period. More than 10 hours of full light daily can encourage excessive algae growth.

- The LED light unit does not require replacement bulbs and should last the life of the tank.

- To maximise light quality, ensure that the clear cover is kept clean.

FILTER MEDIA

Biological Filtration (Filter Sponge)

Biological filtration is a process where toxic nitrogen compounds such as ammonia and nitrite (Fish waste) are removed from the system via a breakdown process carried out by nitrifying bacteria. (Nitrobacter and Nitrosomonas). These nitrifying bacteria need substrate with a high surface area to adhere to such as a sponge.

- When starting a new system it is important to remember that bacterial colony takes time to develop and grow.

- You can speed up the process by 'seeding' the system with Aqua One Bio Starter.

- Over time this media can block up or break down so it is important to monitor it.

Seek advice from your Aquarium Specialist if either of these problems arise.

Mechanical/Chemical Filtration (Carbon Cartridge)

This is the removal of dissolved organic and inorganic substances through adsorption on a porous substrate or by direct chemical removal. Dissolved organic compounds are what turns the water a yellow-brown colour or causes foaming at the surface of the aquarium and need to be removed.

- Remove carbon cartridge if treating fish with medication.

- Replace every 6 – 8 weeks as the carbons adsorption capacity will have depleted.

- Rinse well before placing in the aquarium. (in tap water)

Mechanical Filtration (Filter Sponge)

This is the process whereby suspended solids or particulate matter are removed from the water.

It is important to remove suspended solids not only to improve clarity of the water but also to:

- Avoid smothering the gills with solids such that fish cannot breathe.

- Decrease risk of disease outbreaks - there are high numbers of bacteria associated with suspended organic solids.

- Protect the biological filter material from rapidly becoming clogged.

- Can also act as a biological filter medium by providing sufficient surface area to host beneficial bacteria

Trouble Shooting

If you are in any doubt about the electrical installation or safety of this product you must consult a qualified electrician.

LIGHT UNIT DOES NOT WORK

1. Ensure that the light switch is in an on position.
2. Check light is plugged into power supply and the switch is on.

POWER HEAD WORKING BUT NO / SLOW WATER FLOW

1. Check impeller is in good condition and replace if needed.
2. Make sure water level in aquarium is above the power head. Please note the power head is a water proof unit.
3. Clean impeller, power head and all inlet and outlet pipes.
4. Check that the spray bar is inserted correctly with the end cap at the opposite end to the elbow.

AQUARIUM POSSIBLY LEAKING

1. Clean carbon cartridge as this can create an overflow.
2. Make sure spray bar holes are pointed down onto the carbon cartridge.
3. Make sure water level is not too high (Refer to page 6.)
4. If an air stone is being used check it is not bubbling water over the rim of the aquarium if so turn the air pump down.
5. Make sure the aquarium is sitting on a level surface.
- 6a. Turn off the light unit & filter unit and remove filter media. Mark the water level. Remove any excess water that may be sitting on the edge of the aquarium. Leave for an hour. If water level drops proceed to step 6b.
- 6b. Remove the fish, decorations and gravel. Empty the aquarium and clean the glass **DO NOT WASH IN SOAP OR DETERGENT**. Place a piece of newspaper on a flat level solid surface. Carefully fill the aquarium ensuring not to spill any water on to the newspaper. Leave the aquarium for several hours and then inspect the newspaper for wet patches.

Specifications

Aquarium Model: LifeStyle 21
Dimensions: 33 x 32 x 24cm
Aquarium Volume: 21L
Filter Flow Rate: 200L/hr
Light Wattage: 5.3W
Power Requirements: 220 ~ 240V AC
Suitable: Coldwater, Tropical

Aquarium Model: LifeStyle 29
Dimensions: 38 x 37 x 25cm
Aquarium Volume: 29L
Filter Flow Rate: 360L/hr
Light Wattage: 8.8W
Power Requirements: 220 ~ 240V AC
Suitable: Coldwater, Tropical

Aquarium Model: LifeStyle 52
Dimensions: 51 x 43 x 30cm
Aquarium Volume: 52L
Filter Flow Rate: 450L/hr
Light Wattage: 13.6W
Power Requirements: 220 ~ 240V AC
Suitable: Coldwater, Tropical

Aquarium Model: LifeStyle 76
Dimensions: 60 x 45 x 33cm
Aquarium Volume: 76L
Filter Flow Rate: 450L/hr
Light Wattage: 16.3W
Power Requirements: 220 ~ 240V AC
Suitable: Coldwater, Tropical

Aquarium Model: LifeStyle 127
Dimensions: 80 x 51 x 48cm
Aquarium Volume: 127L
Filter Flow Rate: 1100L/hr
Light Wattage: 22.2W
Power Requirements: 220 ~ 240V AC
Suitable: Coldwater, Tropical

Aqua One Manufacturer Guarantee 1 + 1 Year

The additional 1 Year **Extended Guarantee** applies when you REGISTER online with Aqua One. Register your Extended Guarantee at www.aquaone.com.au

The Aqua One Aquarium purchased must be installed upon a level surface and weight bearing cabinet and there upon level and load bearing flooring (using a level is recommended). The purchaser must consider the total weight of all items when installing an Aquarium which could be up to 1200kg dependant on the model and accessory items chosen. Consider this, 1L of water = 1kg weight.

About this Guarantee

The Manufacturer or Distributor, of Aqua One goods, is collectively known herein as "Aqua One". Please refer to contact details for Aqua One below or on the applicable Aqua One website. Any product that is covered by its own Guarantee (as enclosed with the product) is subject to the conditions of that Guarantee.

Australian Guarantee

Important note: This guarantee applies in addition to the guarantees, rights and remedies conferred by the Australian Consumer Law and other applicable Commonwealth, State and Territory legislation. The guarantee does not exclude, affect or limit those guarantees, rights or remedies, except to the extent that their application may lawfully be excluded or limited.

In particular, our goods come with guarantees that cannot be excluded under the Australian Consumer Law. You are entitled to a replacement or refund for a major failure and for compensation for any other reasonably foreseeable loss or damage. You are also entitled to have the goods repaired or replaced if the goods fail to be of acceptable quality and the failure does not amount to a major failure.

International Guarantee

The benefits given to the purchaser, under Guarantee, are in addition to all other statutory rights and remedies which the purchaser has in respect of goods under legislation in the applicable country of purchase. This Guarantee shall not affect any such rights and should be read subject to such legislation.

1.0. Terms and Conditions of Guarantee.

- 1.1. Aqua One warrants to the purchaser, for 1 Year from date of original purchase, to repair or replace goods where fault is found due to defective materials or faulty workmanship and where goods do not operate in accordance with the instructions.
- 1.2. All claims for repair or replacement must be made at place of purchase.
- 1.3. The original and dated Proof of Purchase (receipt) must be supplied with all goods claims. Please also provide this Guarantee where possible.
- 1.4. The Guarantee covers the Aquarium against gluing breakdown resulting in leakage.
- 1.5. All goods subject to claim under Guarantee should be prepared for transportation in the original packaging or other comparable packaging which offers the same degree of protection.
- 1.6. Where goods are repaired or replaced under Guarantee, these goods are Guaranteed for the remainder of either the original Guarantee or Extended Guarantee period.
- 1.7. Where claims on inspection reveal goods are in normal working order, Aqua One will request reimbursement of all reasonable costs incurred.

2.0. Other Terms and Conditions – Extended Guarantee

- 2.1. The Extended Guarantee period is for an additional 1 Year and commences on expiration of the standard guarantee period.
- 2.2. Application for Extended Guarantee is FREE of any registration cost to the purchaser on completion of the Extended Guarantee questionnaire which is found on the applicable Aqua One website (refer below).
- 2.3. Upon receipt and acceptance of the questionnaire, Aqua One will forward (by way of email) a Certificate of Extended Guarantee to the purchaser.
- 2.4. For more information on how we collect, hold, use and disclose personal information provided to us, please refer to our Privacy Statement on the Aqua One websites or write to our Privacy Officer, in your country of purchase.
- 2.5. Where Aqua One determines goods are being used in a manner contrary to the instructions, specifications or this Guarantee, Aqua One reserves the right to terminate Extended Guarantee for such goods and will provide written notice to the purchaser.

3.0. Exclusions and Limitations

Where permitted by local law, the following exclusions and limitations apply in regard to Guarantee:

- 3.1. Glass breakage, for whatever reason caused after Aquarium purchase.
 - 3.2. Goods claims where fault is due to, but not limited by a) misuse b) neglect c) abuse d) fire or flood e) normal wear and tear f) accidental breakage g) Acts of God h) mains voltage fluctuation or supply problems i) connection to any voltage other than what is stated on the rating plate j) modification or tampering to electrical cord or plug, k) vermin, insects or foreign object l) liquid spillage or submersion of goods not designed to sustain such use or duress.
 - 3.3. Where inspections reveal goods are in normal working order including where noise or vibration is consistent with normal goods operation.
 - 3.4. Attempted repairs or modifications by unauthorised persons, including but not limited to the drilling of holes in the aquarium glass by unauthorised persons.
 - 3.5. Where the goods factory rating plate has been removed, altered, damaged or is rendered illegible.
 - 3.6. Where goods are not installed, operated or maintained in accordance with Aqua One's goods instructions, specifications or this Guarantee.
 - 3.7. Replacement or repair of worn consumables or replacement of lost goods, parts or components.
 - 3.8. Costs associated with goods transportation, removal, installation, postage or cost of insurance.
 - 3.9. Any damage incurred whilst installing, transporting or moving the goods.
 - 3.10. Subject to certain local statutory rights and obligations to the contrary, and this guarantee shall not affect those rights or obligations, where, to the full extent permitted by law: 1. all express and implied warranties and conditions under statute or general law, are expressly excluded and Aqua One, where permitted, will limit liability as follows and at Aqua One's option to: in regard to goods either a) the replacement of goods or supply of equivalent goods b) the repair of goods or the cost of replacing the goods or of acquiring equivalent goods OR in regard to services either c) the re-supply of services d) the cost to re-supply services.
2. Aqua One will not be liable for any loss or damage, including consequential loss or damage either directly or indirectly, or for any incidental expenses, of any kind, and in any way whatsoever.

(1) we recommend the use of an Aqua One Cabinet (sold separately) as specially designed to suit the Aqua One Aquarium purchased.

(2) consider total weight of all items such as: Aquarium, cabinet, water, filtration, gravel/substrate, decorations and other equipment.

(3) consumables include items such as filter media/cartridges, impellers and shafts, light tubes, lamps, bulbs and starters.

(4) due to the extremely fragile nature of glass and glass being the main component of an Aqua One Aquarium, we strongly recommend that you advise your insurer and consider adding this item to your policy.

(5) When moving the Aquarium from its original or subsequent set-up location/s the following should be adhered to prior to moving the aquarium: remove all aquatic fish, animals or plants, filtration, gravel/substrate, decorations, other equipment mounted on or in the aquarium and ALL water. Also separate the Aquarium from the Aquarium cabinet or similar household item.

Aqua One may be contacted in:

Australia
Kong's (Aust.) Pty. Limited
PO Box 863, Ingleburn
1890 NSW Australia
www.aquaone.com.au

Hong Kong
Kong's Aquarium Supplies Co., Ltd
No 31, 3/F Thriving Industrial Centre
26-38 Sha Tsui Road, Tsuen Wan,
Hong Kong
www.aquaone.co.hk

New Zealand
Kong's (NZ) Limited
PO Box 15 - 183, Tauranga
3015 New Zealand
www.aquaone.co.nz

United Kingdom
Kong's (UK) Limited,
C/O Aqua Pacific UK Ltd.
PO Box 268
Romsey Hampshire, SO51 0WW
United Kingdom
www.aquaone.co.uk

This Aquarium is designed to help simplify general fish keeping. Please note, some specialist fish and aquatic animal or plant keeping require certain considerations, prior to purchase, to ensure proper and successful Aquarium keeping. Therefore, **Aqua One recommends, at time of Aquarium purchase, that you consult with your Aqua One Retailer in regard to the suitability of this product for the types of fishes, aquatic animals or plants you may wish to keep.** Special consideration should also be made in regard to filtration, aquarium heater and lighting requirements to ensure they are specific to your application.

Correct Disposal of this product



This marking indicates that this product should not be disposed with other household waste throughout the EU. To prevent harm to the environment or human health from uncontrolled waste disposal, recycle it responsibly to promote the sustainable reuse of material resources. To return your used device, please use the return and collection systems or contact the retailer where the product was purchased. They can take this product for environmental safe recycling.



Inspiring Excellence in Fish Care!

Manufactured in China.
Designed in Australia by Aqua One.
Aqua One and *Aqua One Inspiring Excellence in Fish Care!* are registered trademarks or trademarks.

www.aquaone.com.au