

MariSys 240

Aqua One®

Advance
Technically Superior

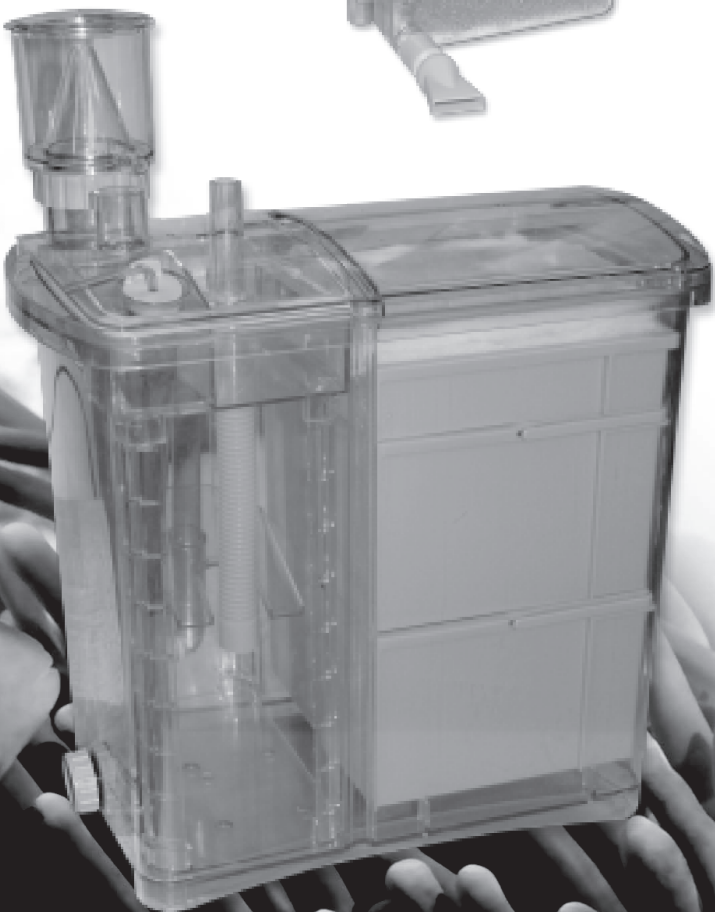
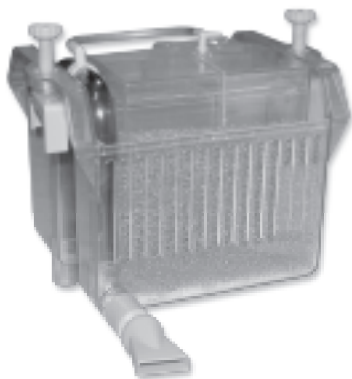

...the step by step... superior...

Important Safeguards

This appliance is not intended for use by children or infirm persons without supervision. Young children should be supervised to ensure that they do not play with the appliance.

Warning: To guard against injury, basic safety precautions should be observed, including the following:

1. Read and follow all safety instructions before using this appliance.

2. Danger: To avoid possible electric shocks, special care should be taken since water is employed in the use of aquarium equipment. For each of the following situations do not attempt repairs yourself. Return the appliance to an authorised service facility for service or discard the appliance.

a) If the electrical components of the appliance get wet, unplug the appliance immediately (non immersible equipment only).

b) If the filter shows any sign of abnormal water leakage, immediately unplug it from the power source.

c) Carefully examine the filter after installation. It should not be plugged in when there is water on parts which are not intended to be wet.

d) Do not operate any filter if it has a damaged cord or plug, or if it is malfunctioning, or dropped or damaged in any manner.

A "drip loop" (See the diagram) should be arranged by the user for each cord connecting an aquarium component to a receptacle. The drip loop is the part of the cord below the level of the receptacle or the connector if an extension cord used. It is used to prevent water traveling along the cord and coming in contact with the receptacle.

If the plug or receptacle does get wet, do not unplug the appliance. Disconnect the fuse or circuit breaker that supplies the power to the appliance, then unplug and examine for presence of water in the receptacle.

3. Close supervision is necessary when the appliance is used by or near children.

4. Always unplug the filter from the electrical outlet; when not in use, before putting on or taking off parts, before any type of maintenance, or cleaning.

Never yank the cord to pull it from the outlet. Grasp the plug and unplug to disconnect.

5. Do not use the filter for reasons other than the intended use. The use of attachments that are not recommended or sold by the filter manufacturer may cause the product to be unsafe. This is not recommended.

6. Do not install or store the filter where it will be exposed to weather or temperatures below freezing.

7. Make sure any component mounted on a tank is securely installed before operating it.

8. Read and observe all the important notices on the filter.

9. Ensure input voltage is the same voltage as your local power supply.

10. If an extension cord is necessary, a cord with a proper rating should be used. Care should be taken to arrange the cord so that it will not be tripped or pulled.

11. A **G.F.C.I** (Ground fault circuit interrupter) & surge protector is recommended for all electrical appliances.

12. Ensure your hand is dry when turning the power switch on/off and when inserting/removing the power cord from the receptacle.

13. If you are in any doubt about the electrical installation or safety of this product you must consult a qualified electrician.

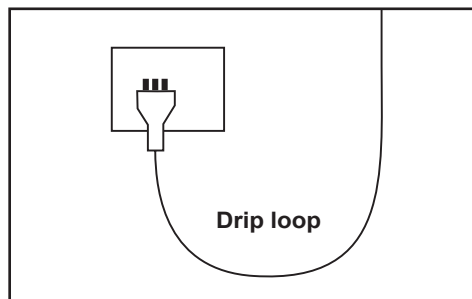

For Guarantee Conditions, please refer to the Guarantee form at the back of this instruction booklet.

Before First Use / Preparation

Read and follow all the instructions, even if you feel you are familiar with the product and find a place to keep the instructions handy for future reference. Your attention is drawn particularly to the sections concerning **“IMPORTANT SAFEGUARDS”** and the **“GUARANTEE CONDITIONS”**. Please ensure you retain your original purchase receipt in the event that guarantee service is required.

Carefully unpack the MariSys, making sure you keep all the packing material until all the parts of the product have been found, and the product has been assembled.

This product is shipped to you in a factory sealed carton. Should the product malfunction in any way or if the unit is damaged and requires replacement, contact the retailer where the product was purchased for inspection.

Know Your Filter

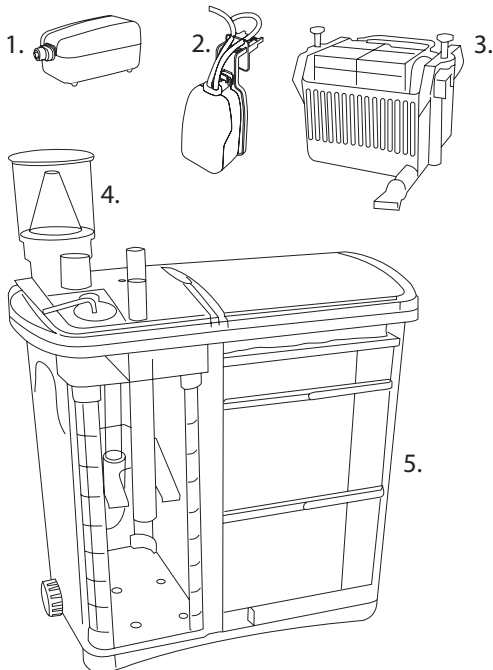

Replacement Parts & Filter Media

Use Aqua One Genuine Spare Parts Only. See your local Aqua One Dealer and look for the number listed below for the spare part you require. Alternatively you will find these numbers on the silver label located on the product.

Impeller	411I
Overflow Pre Filter Pad	413S
3 x Wool Pack	411W
2 x Activated Carbon Pad	411C
2 x Activated Carbon Pillow	412C
2 x Wooden Air Stones	50041

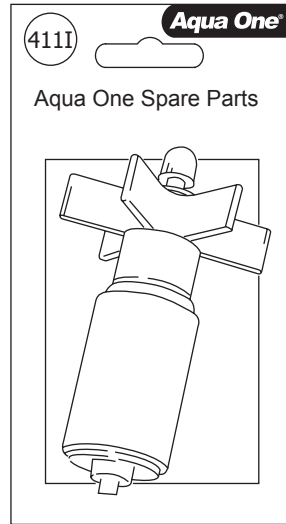

1. Protein Skimmer Air Pump
2. Priming Pump
3. Overflow Box
4. Protein Skimmer
5. MariSys

Recommended Filter Media Set Up

MariSys



Drip Tray

Media Basket 1

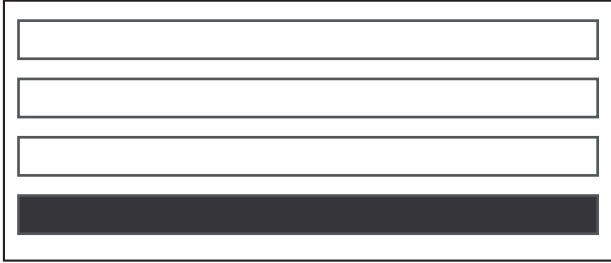

Wool
(x 3)

Activated Carbon
Pad

Media Basket 2

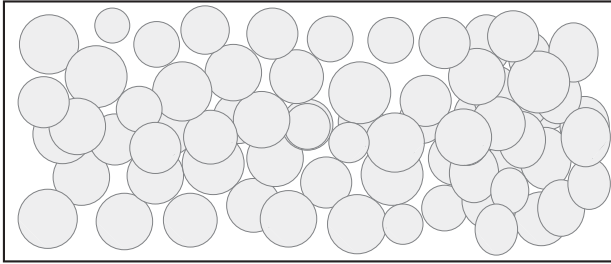

Bio Balls

Media Basket 3

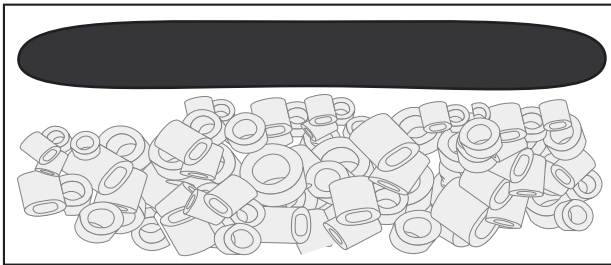

Activated Carbon
Pillow

CeramiSub

Please Note: This filter media set up above is a guide. For more information regarding filter media please consult your Aqua One specialist.

1. MariSys Complete System. (Diagram 1)

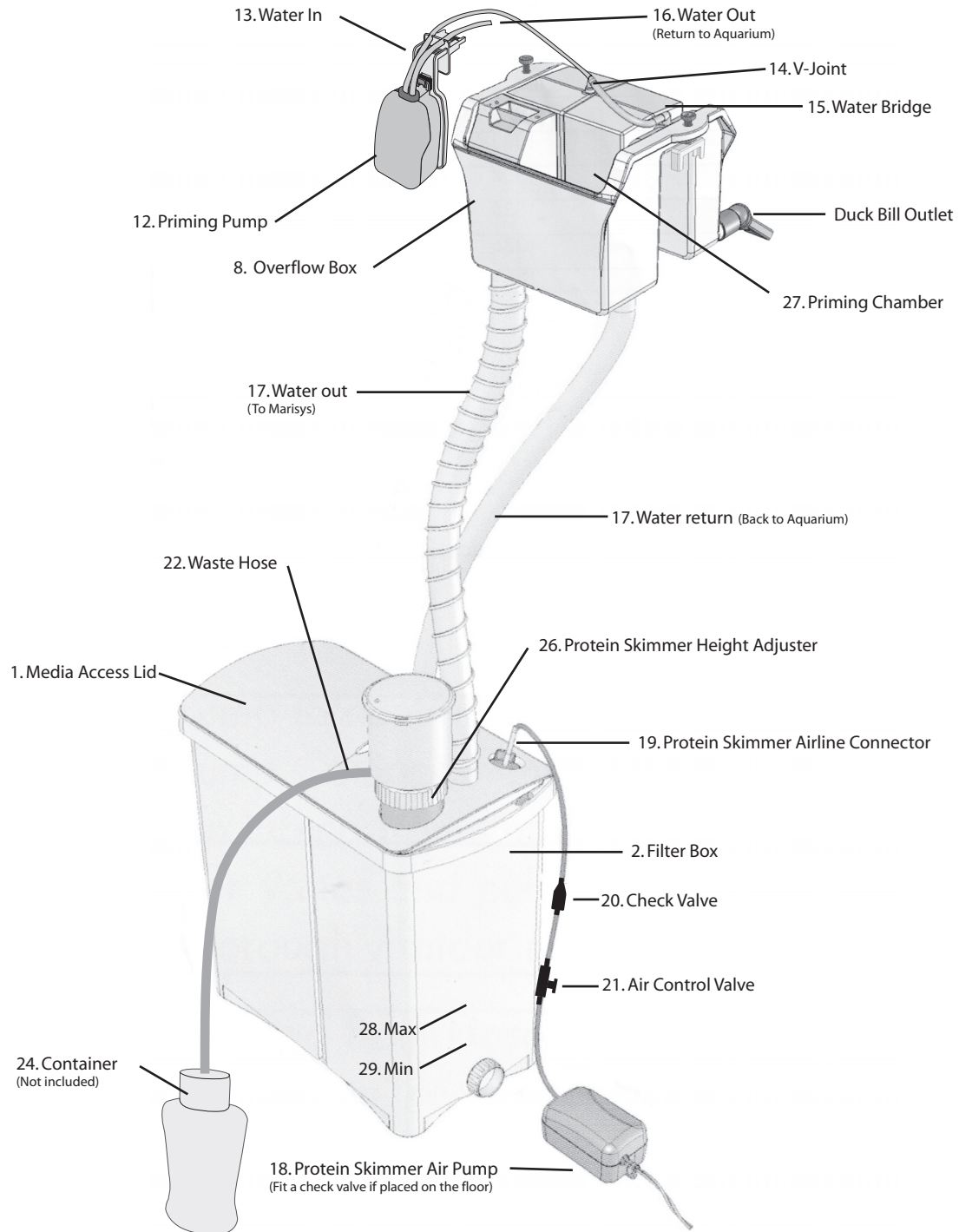

2. MariSys. (Diagram 2)

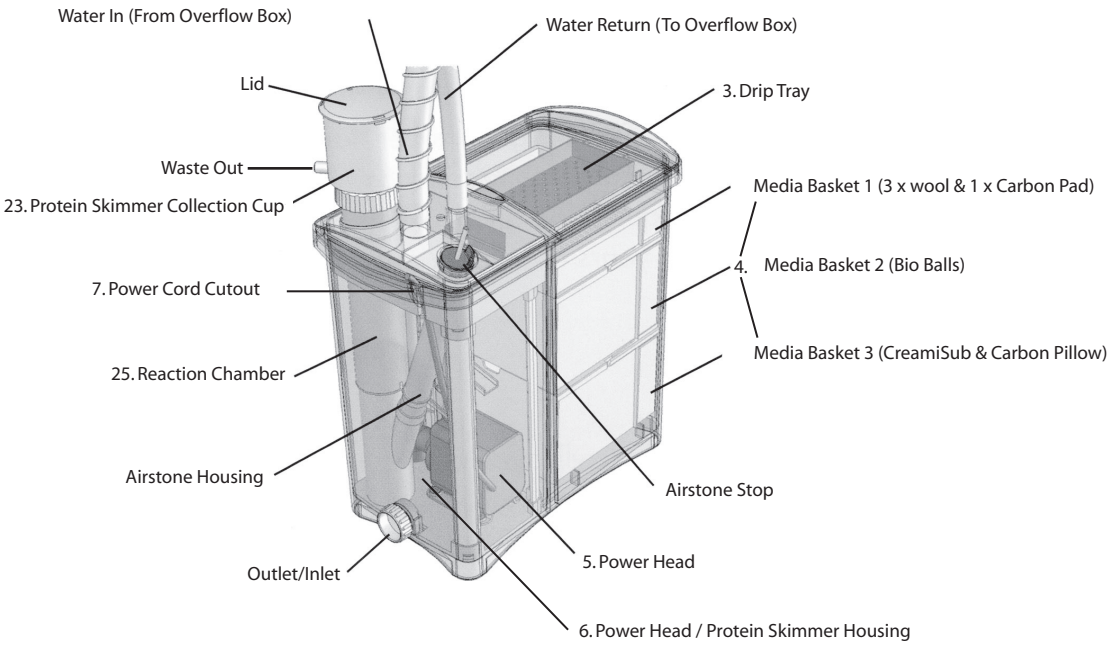

3. Overflow Box. (Diagram 3)

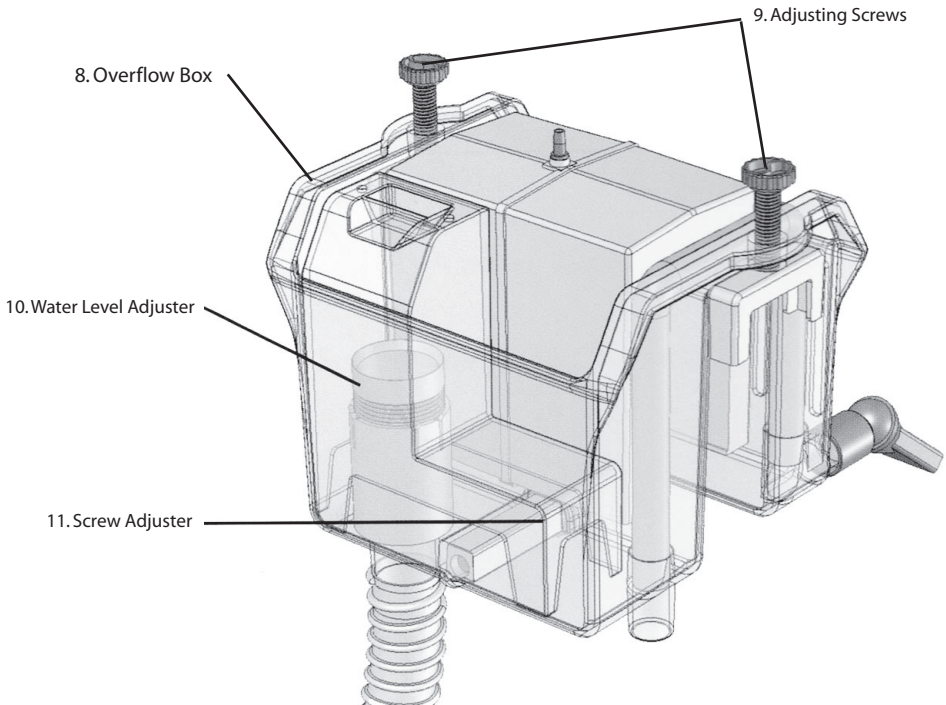

Set Up Instructions

Setting up the Filter Media

For the following section refer to Diagrams 1 & 2 on pages 3,5 & 6 of this instruction booklet.

Locate and organise all parts before assembly. Familiarise yourself with the parts and where they fit. (Refer to the Quick Set Up Guide and Exploded View sheet) The only tools you will need to assemble your MariSys Filter are a flathead screwdriver, a utility knife and a tape measure.

1. Remove the Media Access Lid (1) from the top of the Filter Box (2), lift and remove the Drip Tray (3).
2. Lift the handles and remove all of the Media Baskets (4) from the Filter Box and take them to the sink.
3. Ensure there is no soap or any other residue around the sink area.
4. Remove the Carbon Pillow and CeramiSub from the plastic bag, rinse them along with all of the other filter media under tap water.
5. Refer to the diagram on page 4 for the correct placement of the media and the order in which they should be placed in the Filter Box.
6. Return the Media Baskets to the Filter Box.
7. Do not replace the Drip Tray or Media Access Lid yet.

Setting up the Power Head

For the following section refer to Diagram 2 on page 5 of this instruction booklet.

1. Remove the Power Head (5) from the box marked PUMP.
2. Check the Intake Elbow is firmly inserted and facing downwards.
3. Ensure your hand is dry and plug the Power Head in to ensure it is working. DO NOT stick fingers or inanimate objects into the pump if it does not work. Refer to the Maintenance section of this booklet for instruction on disassembling the unit.

4. Remove the Power Head / Protein Skimmer Housing (6) from the Filter Box.
Please Note: This may be a tight fit.

5. Connect the Flexible Tubing to the Outlet of the Power Head. Ensure it is connected correctly.

6. Insert the Power Head into the Housing. You will notice there are 4 holes where the rubber feet on the Power Heads Base are intended to sit.

7. Feed the Power Cord through the Housing. You will notice the Power Cord Cutout (7) near the top of the Airstone Housing.

8. At the top of the housing there is a blue O-ring. Lubricate this with an aquarium safe lubricant. This will improve the seal and allow the Housing to be removed easier when maintenance is required.

9. Slide the Power Head / Protein Skimmer Housing back into the Filter Box. Be sure the Power Cord from the Power Head is feed through the Power Cord Cutout.

10. DO NOT FORCE the unit together. If it feels tight lift the Housing back out and try again.

11. Place the Drip Tray back ontop of the Media Baskets and refit the Media Access Lid.

Setting up the Overflow Box

For the following section refer to Diagrams 1 & 3 on pages 5 & 6 of this instruction booklet.

1. Position the MariSys in the stand / cabinet under the aquarium or to the side next to the stand.
2. Place the Overflow Box (8) on the rear or side of the aquarium. Initially the height of the box should be at its lowest setting. The two Adjusting Screws (9) on each side will allow for the Overflow Box to be raised or lowered.

To lower the aquarium's water level, turn the adjusting screws anti-clockwise, this will reduce the height of the Overflow Box To raise the water level in the aquarium, turn the adjusting screws clockwise to move the box back up.

Set Up Instructions

The aquarium's water level can also be raised or lowered by adjusting the Water Level Adjuster. (10) Raising the tube will cause the aquarium's water level to rise and lowering the Water Level Adjuster will cause the aquarium's water level to drop.

3. Remove the pre-filter pad, rinse it under water and place back into the Overflow Box.

4. Turn the Screw Adjuster (11) located at the bottom of the Overflow Box to level it.

5. Position the Priming Pump (12) with hanger next to the Overflow Box on the aquarium's rim. Connect one end of the airline tubing to the Priming Pump "in" (13) port (indicated by the arrow which points towards the Priming Pump on the red connection adapter). Connect the other end of the airline tubing to the V-Joint (14) located at the top of the Water Bridge. (15)

6. Connect the second piece of airline tubing to the "out" (16) port of the Priming Pump (indicated by the arrow pointing away from the Priming Pump on the red connection adapter) and secure the other end of the airline back into the aquarium. It is very important to ensure this hose does not dislodge as it will drain the aquarium.

7. Measure the distance from the Overflow Box to the MariSys. Be accurate so you do not cut the hose too short. (Measure twice and cut once) Take the utility knife and cut the Large and Small Flexible Hosing (17) to the desired length.

The Flexible Hosing must follow a straight path from the Overflow Box to the MariSys. There can be a little slack but not too much or the filter will not operate correctly.

8. Place a Hose Clamp over the end of each piece of Flexible Hose and slide the Flexible Hosing over the outlet and inlet, located on the base of the Overflow Box. Do not tighten the Hose Clamps yet.

9. Do the same for the connections at the top of the MariSys.

10. Once every thing is in position tighten the hose clamps so it is a snug fit. **DO NOT OVER TIGHTEN** them as you may crack the plastic.

Setting up the Protein Skimmer

For the following section refer to Diagrams 1 & 2 on pages 5 & 6 of this instruction booklet.

1. Set the Protein Skimmer Air Pump (18) in the cabinet next to the MariSys or on top of it. It is recommended that the Air Pump always be positioned higher than the wooden airstone. Your MariSys is supplied with a Check Valve, this ensures water does not back siphon into the Protein Skimmer Air Pump. This allows you to place the Air Pump on the base of the cabinet next to the MariSys.

Please Note: All attachments are inserted into the Airline during production. Simply attach the blue adapter to the Protein Skimmer Air Pump and the other end to the Protein Skimmer Airline Connector (19). Step 2 can be ignored during set up and referred if needed at a later date during maintenance.

2. Connect one end of the airline tubing to the Protein Skimmer Airline Connector (19) and the other end to Check Valve (20). Connect the second piece of airline tubing from the Check Valve to the Air Control Valve (21), and then the third from the Air Control Valve to the blue adapter which fits over the 2 outlets of the Protein Skimmer Air pump.

3. Connect the Waste Hose (22) to the outlet at the base of the Protein Skimmer Collection Cup (23), then place the other end of the tubing into an empty 1 litre Container. (Not supplied) (24)

4. The height of the wooden airstone has been preset; the bent portion on the rigid tubing of the Airline Connector is at the recommended setting.

To raise or lower the airstone, grasp the rigid tubing and gently turn left or right while pushing down or pulling up.

If the airstone is positioned too high in the Reaction Chamber, (25) the air bubbles will overflow and fill the Collection Cup. Under normal conditions, the airstone should be positioned about 1.5 – 2cm from the bottom of the Reaction Chamber.

Set Up Instructions

5. When the aquarium is newly set up, it may take a couple of days for the Protein Skimmer to begin producing waste. Once the Skimmer is functioning properly, check the settings of the Protein Skimmer daily by viewing the amount of bubbles in the Reaction Chamber.

A. If the bubbles are too few and there's not any waste accumulating in the Collection Cup, gradually open the Air Control Valve. Adjust the screw a quarter turn and then wait 5 minutes. If still too few, turn the screw another quarter turn. It is best to adjust slowly to achieve the desired level of bubbles.

B. If there are too many bubbles and the Collection Cup is overflowing rapidly, slowly close the Air Control Valve to achieve desired bubble flow.

6. To further adjust and fine tune the Protein Skimmer, loosen the Height Adjuster (26) located at the base of the Collection Cup anti clock-wise until it is free. Pull the Collection Cup up.

There is a thin O-ring found directly under the Height Adjuster. Roll the O-ring up or down depending on the need of adjustment.

Normally the Collection Cup is raised upward to control and firm up the layer of bubbles pushing up through the small tube in the Collection Cup or if the air bubbles are too strong and are overflowing too quickly into the Collection Cup.

7. Change the wood airstone every 2 to 3 months or as needed. The size of the air bubbles will become larger as the airstone ages and the Protein Skimmer will become less effective in removing wastes.

Please Note: Every time the airstone is replaced monitor the Protein Skimmer, as the bubble size will have changed with the new stone and it may require adjusting.

Starting the Filter

1. Ensure you aquarium is full of water.
2. Fill the Priming Chamber (27) of the Overflow Box with water until the water begins to travel down the Flexible Hosing and into the MariSys.

3. Remove the Media Access Lid from the MariSys and fill the unit with water until it is about 1cm above the Maximum water level indicator. (28)

4. Plug in the three power cords

- a. Power Head,
- b. Priming Pump and
- c. The Protein Skimmer Air Pump

into a standard power board. Be sure to form a "drip loop". (Refer to page 2)

Turn the power on.

The Overflow Box will automatically start drawing water and the MariSys will begin to fill with water. Check for leaks at this time.

5. Check the water level in the Filter Box. If the water level is lower than the Minimum Level, (29) add water to bring it back up to the Maximum level. When the water level is below the minimum mark the Power Head will start to draw air and propel too many air bubbles back into the aquarium.

Maintenance

To ensure optimum filter performance, routine maintenance should be performed monthly or less depending on size of tank, amount of fish and number of daily feeding. If the filter and media are neglected, the filter media will become clogged and unable to collect waste material. This can affect aquarium water quality and possibly the health of the tank inhabitants. Grimy waste can also damage the Priming Pump, Power Head and also diminish the filter efficiency.

Please Note: It is best to turn the system off whenever any maintenance is performed on the MariSys or Overflow Box.

Do not use soap or detergents that can harm the tank inhabitants.

The Filter Wool should be changed or rinsed every two to three weeks or as needed. The Activated Carbon Pad should be replaced monthly when there is a normal bio-load.

Replacing Filter Media

1. Remove the Media Access Lid and Drip Tray.
2. Remove the Media Basket containing the Filter Wool and Carbon Pad. Hold the Media Access Lid under the Media Basket to keep the water from splashing on the floor while transporting it to the sink.

Ensure there is not soap or other residue around the sink area.

3. Take the Media Basket to the sink and remove all of the Filter Wool Pads and the Carbon Pad.
4. Rinse the Media Baskets under cool running water.
5. Place the new Carbon Pad at the bottom of the Media Basket followed by the rinsed or new Wool Pads.
6. Replace the Carbon Pillow every four weeks or less, depending on number of aquatic animals, discoloration or cloudy water and the amount of daily feeding.
7. The Bio Balls and CeramiSub should not be washed under tap water at any stage. They can be dunked in a bucket of aquarium water if they are extremely dirty. Replace 1/3rd of the CeramiSub every 12 months as the media can clog and stop working effectively.

Consult your Aqua One specialist for further advice on maintaining your biological media.

Power Head Maintenance

The Power Head should be disassembled and cleaned on a monthly basis. Refer to the Diagram on page 11 for the following instructions.

1. Turn off all power and unplug the Power Head before servicing the unit.
2. Remove the Media Access Lid.
3. Take hold of the Power Head / Protein Skimmer Housing and pull gently upward to expose the Power Head for servicing.
4. Hold the Power Head and remove the Inlet Elbow.
5. Gently turn the Impeller Cover Lock anti-clock wise to remove it.
6. Pull the Impeller Cover away from the Motor. This will be a tight fit.
5. Clasp the Impeller Blades with needle nose pliers and slowly pull the Impeller from the Impeller Well.
6. Clean Impeller under warm running water. Do not use soap or detergent. Remove the Rubber End Caps and Ceramic Shaft and run clean water through the hole in the center of the Impeller.
7. Use an Aqua One Double Ended Pipe Brush to clean the Impeller Well thoroughly. (Where the impeller sits in the Motor)
8. Reassemble in the reverse order, ensure an aquarium safe lubricant is used to lubricate the O-ring on the Impeller Cover.

Priming Pump Maintenance

1. Flush the Priming Pump whenever the Power Head is maintained.
2. Disconnect the Pump from the V - Joint on top of the Water Bridge, leave the Air line attached to the Pump.
3. Fill a small container with clean fresh tap water.
4. Set the Pump up so that both of the air line ends are in the water.
5. Turn the Pump on and allow it to circulate with for around 10 minute.
6. After 10 Minutes switch the Pump off and reconnect it to the system.

Cleaning your Power Head

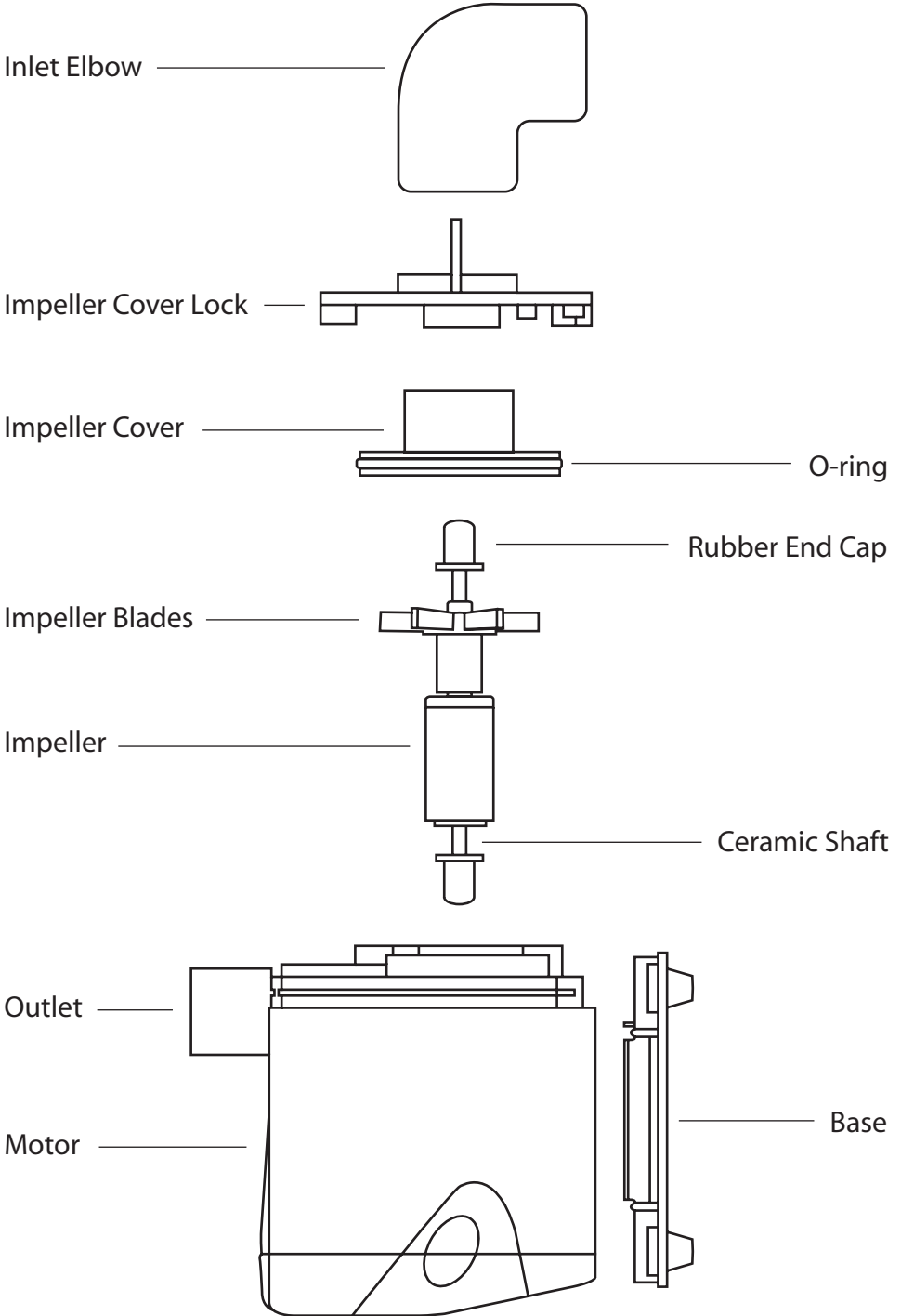

Trouble Shooting

NO WATER CIRCULATION

1. Check power supply and confirm Power Head is plugged in.
2. No water in Filter Box, add water to Maximum Water level indicator.
3. Check Overflow Box to confirm water is flowing.
4. Check the Pre Filter at the front of the Overflow Box and clean if needed.

LARGE AMOUNT OF BUBBLES ARE BEING PUMPED BACK INTO TANK

1. Check water level in the MariSys, add water if needed.
2. Check Overflow Box for obstacles.
3. Check Hosing and Tubing for kinks or obstructions.
4. If using air stones or power heads with venturi installed, position away from Overflow Box inlet.

RETURN WATER FLOW IS SLUGGISH.

1. Check Overflow Hosing or return Hosing for kinks; straighten Hosing and/or tubing if needed.
2. Check for obstructions in Overflow Box or inlet of Power Head.
3. Check the Power Head.

POWER HEAD NOT RUNNING

1. Check the Power Head is plugged in and has electrical power.
2. Check Impeller in Power Head to confirm it is rotating freely. Refer the Maintenance section in this instruction booklet.

WATER LEAKING AT FLEXIBLE HOISING CONNECTIONS

1. Disconnect Flexible Hoses from connectors on the MariSys and Overflow Box and clean connectors thoroughly with an Aqua One Double Ended Pipe Brush. Reconnect and tighten hose clamps snugly.
2. If the Flexible Hosing has slipped from original position, remove and clean area, then reconnect and tighten hose clamps snugly.

PROTEIN SKIMMER NOT FUNCTIONING

1. If the Filter is newly set up, it may take a couple of days for the Skimmer to start collecting waste.
2. Confirm Air Pump is plugged in.
3. Confirm Air Pump is connected to Wood Airstone Rigid Airline Tubing.
4. The Wooden airstone may need to be replaced.

NO FOAM PRODUCTION IN THE COLLECTION CUP

1. Aquarium is not established yet and has not produced enough dissolved organics.
2. Wood airstone needs to be replaced.
3. Skimmer is in break-in period, should work in 3 days.

SUDDEN OR GRADUAL LOSS OF AIRSTONE BUBBLES

1. Possible clogged airline, remove airline tubing and run under hot water thoroughly.
2. Wood airstone needs to be replaced.
3. Check the Air Control Valve and Check Valve.

Trouble Shooting

LARGE AMOUNTS OF BUBBLES AND WATER ARE BEING PROPELLED INTO THE COLLECTION CUP

1. Reduce air supply to Skimmer by adjusting Air Control Valve.
2. If bubbles and water are still rapidly filling the cup, unscrew the Skimmer Height Adjuster and lower the O Ring 1.5cm. Raise the Collection Chamber upward 2.5cm and reassemble.

PROTEIN SKIMMERS BUBBLES ARE TOO LARGE

1. Wood airstone needs to be replaced.
2. Adjust Air Control Valve a quarter turn clockwise to close and then wait 5 minutes, if still too big turn the screw another quarter turn.

PROTEIN SKIMMER'S BUBBLES ARE TOO SMALL

1. Adjust Air Control Valve a quarter turn anti-clockwise to open and then wait 5 minutes, if still too few turn the screw another quarter turn.

PROTEIN SKIMMER AIR PUMP IS BECOMING NOISY

1. Check wood airstone to see if it is still producing large amount of bubbles, replace wood airstone as airstone wears.
2. Replace diaphragms in the Protein Skimmer Air Pump with new ones.
3. Check air line for kinks.
4. Check the Air Control Valve and Check Valve.

OVERFLOW BOX NOT FUNCTIONING

1. Check power supply and confirm Priming Pump is plugged in.

2. No water in Overflow Box, add water.
3. Check Overflow Box for obstacles.
4. Check Hosing and Tubing for kinks or obstructions.

PRIMING PUMP NOT RUNNING

1. Check power supply and confirm Priming Pump is plugged in.
2. Ensure the airline is correctly inserted into the red ports on the Priming Pump. Arrow in is water in from the V-Joint on the Water bridge.
3. Open Priming Pump Housing and confirm diaphragm is moving.
4. Replace Priming Pump Diaphragm and Flappers with new rebuilt kit.

PRIMING PUMP RUNNING BUT WATER FLOW IS MINIMAL

1. Possible clogged airline, remove airline tubing and run under hot water through or replace and reinstall.
2. Replace Priming Pump Diaphragm and Flappers with new rebuilt kit.

WATER LEVEL IN FILTER BOX TO HIGH

1. Raise height of Overflow Box by turning height Adjusting Screws clockwise.
2. Raise height of Overflow Box by adjusting the Water Level Adjuster.
3. Remove some water from aquarium.

Aqua One - Guarantee 2 + 2 Year

Congratulations on your purchase of a quality Aqua One product. This product will last for many years under normal usage the guarantee commences from the day of purchase. You must provide proof of purchase when you submit your equipment for repair under guarantee.

The benefits given to the purchaser by the manufacturers guarantee are in addition to all other rights and remedies which the purchaser has in respect of the equipment under the legislation of the appropriate country of purchase.

Your 2 year guarantee can be extended by a further 2 years upon registration with the distributor. This can be done online at the address below or by completing the extended guarantee registration card and returning by post to the address of your country of purchase.

www.aquaone.com.au

General Guarantee Conditions:

1. All claims for guarantee service should be made to the place of purchase.
2. You must provide proof of purchase when you submit your equipment for repair under guarantee.
3. This guarantee extends only to defects occurring in materials or workmanship under normal use of the equipment when operated in accordance with the supplied instructions.
4. Replacement equipment is guaranteed for the remainder of the original manufacturer's guarantee period.

Guarantee does not cover:

- a. Cost of freight, postage or the cost of insurance.
 - b. Service costs arising from failure to correctly adjust the controls of the product or to clean the hoses, filter media, impellers, power heads, failure to observe the manufacturer's instructions or inspections that reveal that the equipment is in normal working order.
 - c. Equipment failures caused by misuse, neglect, normal wear and tear, accidental breakage, repairs or modification by unauthorised persons, lightning strikes, mains voltage fluctuation, earthquakes, vermin infestation or liquid spillage.
 - d. Consumables, such as impellers, shafts, filter pads, filter media, sponges, wool, diaphragms, flapper valves and airstones.
 - e. In no event will the manufacturer or distributor of that country be liable for any consequential or incidental damage including, but not limited to loss of livestock, property damage, damage to equipment, appliances or furnishings arising from the use of this product or from failure of this product.
 - f. Damaged incurred in transit resulting from inadequate packing.
5. It is recommended that all equipment subject to claim should be prepared for transportation in its original packaging or other suitable packaging which offers the same degree of protection.



Are your fish telling You something?

- Due for a water change?
- Maintenance required?
- How is your aquarium water quality?



Aqua One Test Kits



Keep an accurate and up to date record of your aquarium using the Aqua One Test Kit Log Book

www.aquaone.com.au