



Important Safeguards

This appliance is not intended for use by children or infirm persons without supervision. Young children should be supervised to ensure that they do not play with the appliance.

Warning: To guard against injury, basic safety precautions should be observed, including the following:

1. Read and follow all safety instructions before using this appliance.

2. Danger: To avoid possible electric shocks, special care should be taken since water is employed in the use of aquarium equipment. For each of the following situations do not attempt repairs yourself. Return the appliance to an authorised service facility for service or discard the appliance.

a) If an appliance falls into water, do not reach for it, unplug it and then retrieve it. If the electrical components of the appliance get wet, unplug the appliance immediately (non immersible equipment only).

b) If the aquarium shows any sign of abnormal water leakage, immediately unplug all accessories from the power source.

c) Carefully examine the filter after installation. It should not be plugged in when there is water on parts which are not intended to be wet.

d) Do not operate any aquarium accessory if it has a damaged cord or plug, or if it is malfunctioning, or dropped or damaged in any manner.

A "drip loop" (See the diagram) should be arranged by the user for each cord connecting an aquarium component to a receptacle. The drip loop is the part of the cord below the level of the receptacle or the connector if an extension cord is used. It is used to prevent water traveling along the cord and coming in contact with the receptacle.

If the plug or receptacle does get wet, do not unplug the appliance. Disconnect the fuse or circuit breaker that supplies the power to the appliance, then unplug and examine for presence of water in the receptacle.

3. Close supervision is necessary when the appliance is used by or near children.

4. Always unplug the filter from the electrical outlet, when not in use, before putting on or taking off parts, before any type of maintenance,

or cleaning. Never yank the cord to pull it from the outlet. Grasp the plug and unplug to disconnect.

5. Do not use the filter for reasons other than the intended use. The use of attachments that are not recommended or sold by the filter manufacturer may cause the product to be unsafe. This is not recommended.

6. Do not install or store the filter where it will be exposed to weather or temperatures below freezing.

7. Make sure any component mounted on a tank is securely installed before operating it.

8. Read and observe all the important notices on the filter.

9. Ensure input voltage is the same voltage as your local power supply.

10. If an extension cord is necessary, a cord with a proper rating should be used. Care should be taken to arrange the cord so that it will not be tripped or pulled.

11. A **G.F.C.I** (Ground fault circuit interrupter) & surge protector is recommended for all electrical appliances.

12. Ensure your hand is dry when turning the power switch on/off and when inserting/removing the power cord from the receptacle.

13. If you are in any doubt about the electrical installation or safety of this product you must consult a qualified electrician.

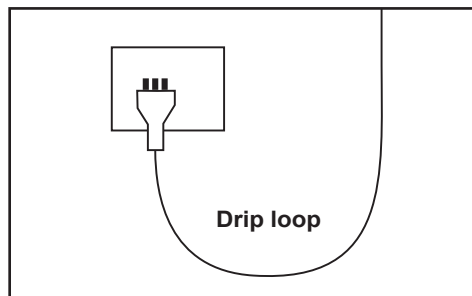

For Guarantee Conditions, please refer to the Guarantee form at the back of this instruction booklet.

Important Safeguards

Connecting your appliance to the mains electricity supply - Country specific instructions.

United Kingdom

The plug supplied with this product is a sealed plug and we do not recommend removing or changing it. However, should the need arise, only a suitable plug should be connected using the following diagram 1

An approved earth leakage circuit breaker (RCCB) or otherwise known as an Residual circuit current device (RCCD) must be also fitted in the supply line.

IF YOU ARE IN ANY DOUBT ABOUT INSTALLING YOUR APPLIANCE YOU SHOULD CONSULT A QUALIFIED ELECTRICIAN.

Australia, New Zealand and Hong Kong

In Australia, New Zealand and Hong Kong all products are supplied with fitted plugs. This plug should **NOT** be tampered with in any way or removed. Removal or tampering with the plug invalidates our guarantee offered with this product.

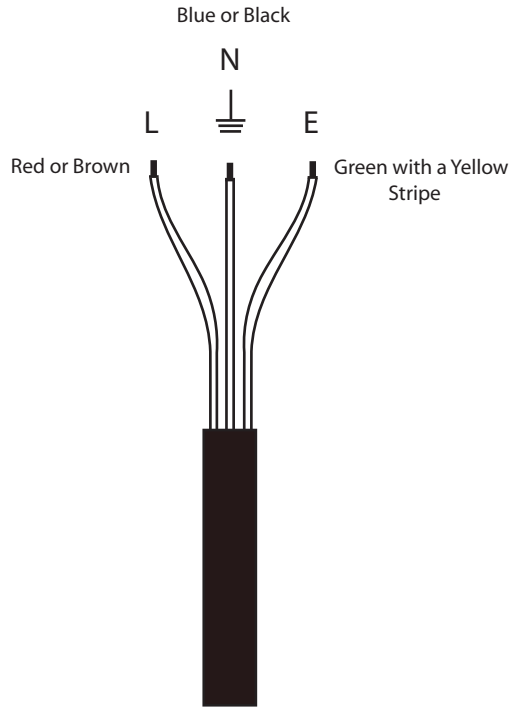

Diagram 1

Before First Use / Preparation

Read and follow all the instructions, even if you feel you are familiar with the product and find a place to keep the instructions handy for future reference. Your attention is drawn particularly to the sections concerning “**IMPORTANT SAFEGUARDS**” and the “**GUARANTEE CONDITIONS**”. Please ensure you retain your original purchase receipt in the event that guarantee service is required.

Carefully unpack the filter making sure you keep all the packing material until all the parts of the product have been found and the product has been assembled.

This product is shipped to you in a factory sealed carton. Should the product malfunction in any way or if the unit is damaged and requires replacement, contact the retailer where the product was purchased for inspection.

Correct Positioning In Aquarium

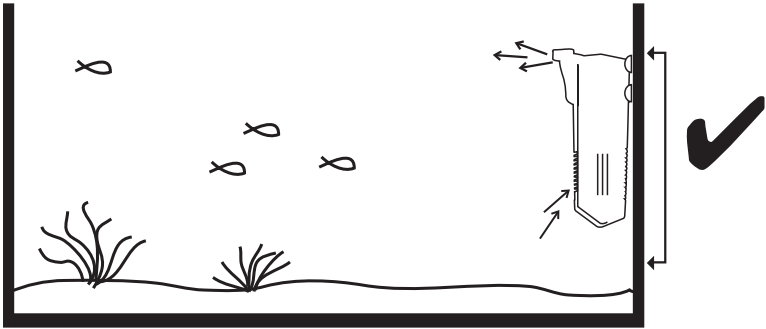

Set the filter up within the arrows indicated above.

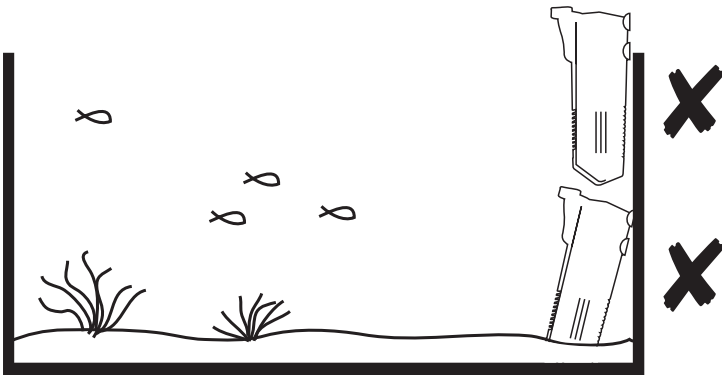

Filter must not be out of the water and must not be in contact with any substrate.

Know Your Filter 300F - LV

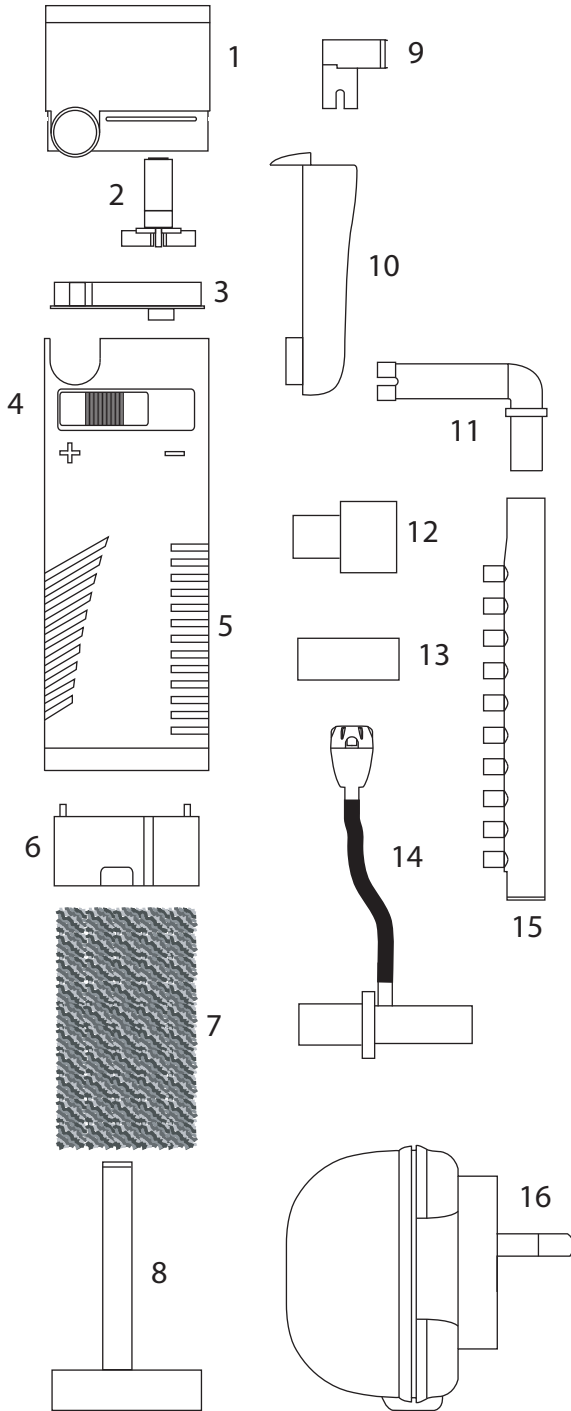

1. Motor
2. Impeller
3. Impeller Cover
4. Flow Controller
5. Sponge Casing
6. Carbon Cartridge
7. Sponge
8. Sponge Holder
9. Duckbill Outlet
10. Outlet Adapter
11. Spray Bar Elbow
12. 13mm Outlet
13. 9mm Outlet
14. Venturi Outlet With Venturi & Air Line
15. Spray Bar
16. Transformer

Replacement Parts & Filter Media

Use Aqua One Genuine Spare Parts Only. See your local Aqua One Dealer and look for the number listed below for the spare part you require. Alternatively you will find these numbers on the silver label located on the product.

300F Sponge	34S
300F Impeller	34I
300F Carbon Cartridge	34C

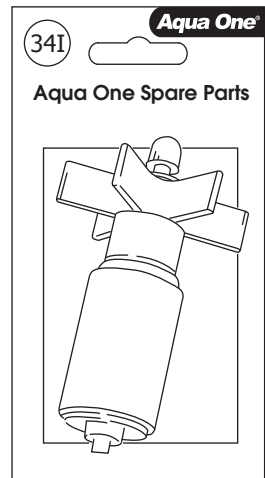

Know Your Filter 301F - LV

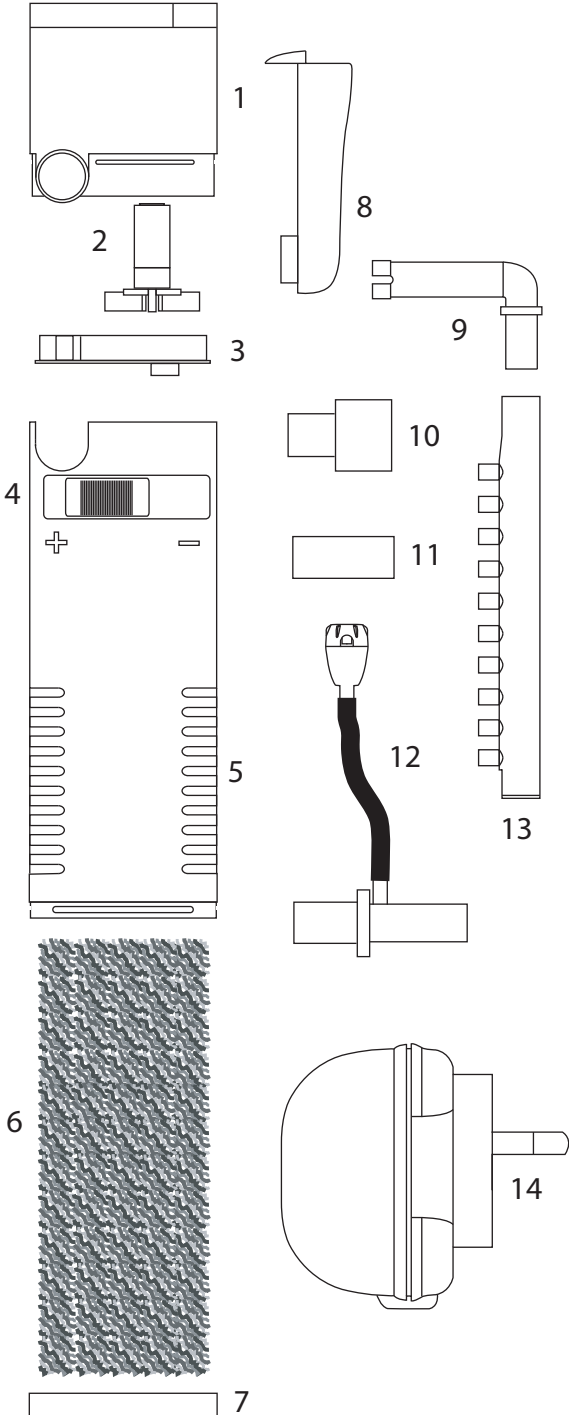

1. Motor
2. Impeller
3. Impeller Cover
4. Flow Controller
5. Sponge Casing
6. Sponge
7. Sponge Casing Base
8. Outlet Adapter
9. Spray Bar Elbow
10. 13mm Outlet
11. 9mm Outlet
12. Venturi Outlet With Venturi & Air Line
13. Spray Bar
14. Transformer

Replacement Parts & Filter Media

Use Aqua One Genuine Spare Parts Only. See your local Aqua One Dealer and look for the number listed below for the spare part you require. Alternatively you will find these numbers on the silver label located on the product.

301F Sponge	35S
301F Impeller	35I

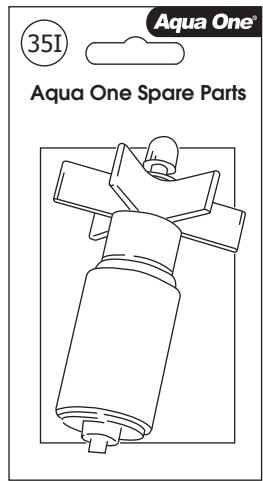

Know Your Filter 302F - LV

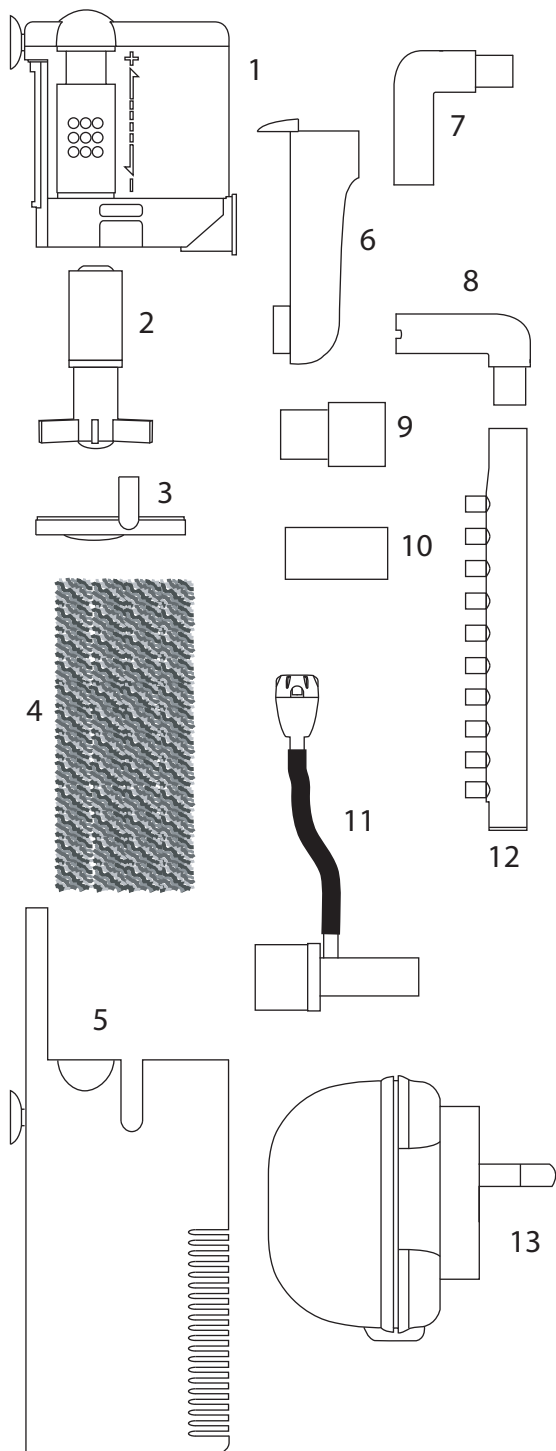

1. Motor
2. Impeller
3. Impeller Cover
4. Sponge
5. Sponge Casing
6. Outlet Adapter
7. Outlet Elbow
8. Spray Bar Elbow
9. 13mm Outlet
10. 9mm Outlet
11. Venturi Outlet With Venturi & Air Line
12. Spray Bar
13. Transformer

Replacement Parts & Filter Media

Use Aqua One Genuine Spare Parts Only. See your local Aqua One Dealer and look for the number listed below for the spare part you require. Alternatively you will find these numbers on the silver label located on the product.

302 Sponge
302 Impeller

36S
36I

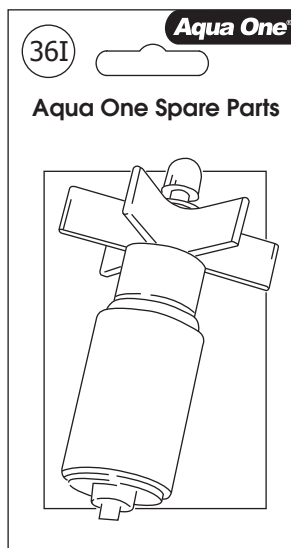

Installation 300/301-LV

All of the smaller models are low voltage with the transformer located on the plug. They come fully assembled and are ready to use.

1. Decide on which outlet option to use.

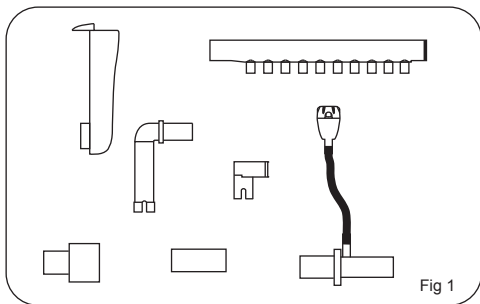

a) If no attachment is required simply push the 13mm or 9mm outlet into the pump outlet.

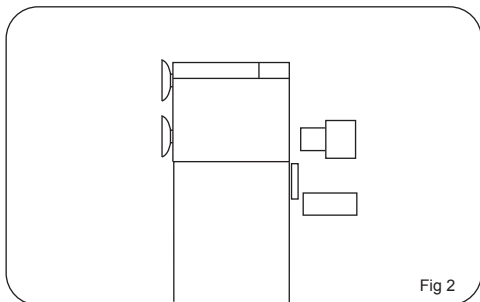

b) If the venturi is required, push venturi outlet directly into pump outlet, hang airline outside of your aquarium.

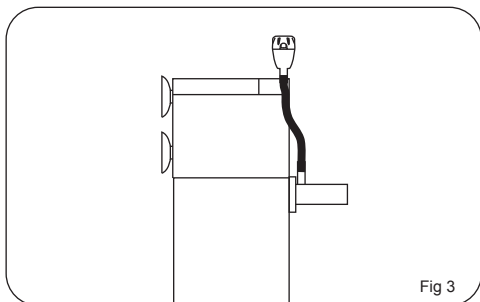

c) If the spray bar, or duckbill is to be used, push upright adaptor directly into pump outlet adapter then either; connect spray bar with elbow into top

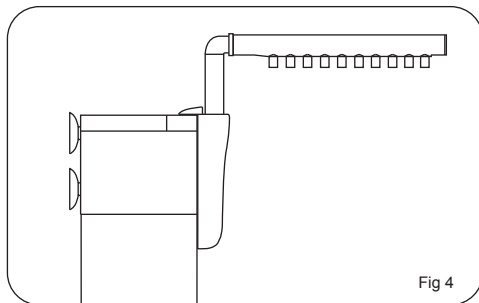

OR use the duck bill on the outlet adaptor. (Not included with 301F-LV)

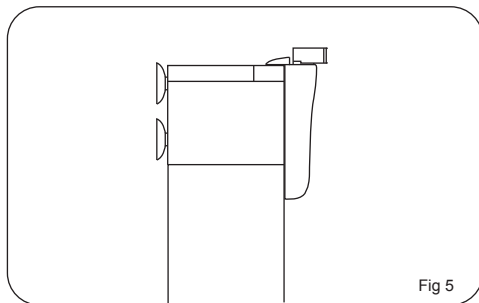

2. Suction cups will fasten the filter to the wall of your aquarium. It is best to have surface agitation if it is being used as the sole filter.

3. Use flow adjuster on the front of the filter:

- + will allow full flow
- will reduce the flow

Remember the more flow the better.

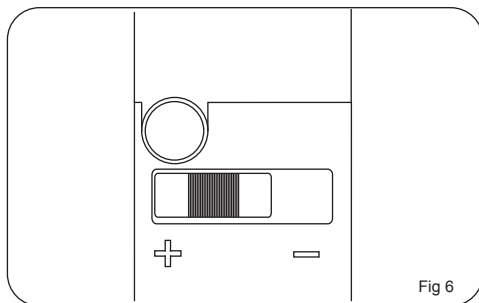

Maintenance 300/301-LV

1. Unplug from the power supply. Take to sink.

2. Remove the sponge casing base or sponge holder (depending on your model) from the base of the filter to access the filter sponge.

3. Remove sponge and squeeze gently a few times in a bucket of aquarium water. It is important to not wash the sponge too thoroughly and never wash it in tap water.

4. On model 300-LV only, rinse the carbon cartridge under tap water. The carbon cartridge will unclip from the two support brackets.

Carbon cartridges need to be replaced every 3-4 weeks.

Accessing The Impeller

Clean the impeller at least once a month.

1. Grasp the motor with one hand and filter casing with the other and gently pull apart.

2. Remove the impeller cover to gain access to the impeller.

3. Pull impeller from the motor and rinse properly. Use an *Aqua One* double ended pipe brush to clean the impeller and the impeller well and also any of the outlet options that are being used.

4. Put the filter back together and return to the aquarium. Ensure your hand is not wet, plug in at the power supply and turn on.

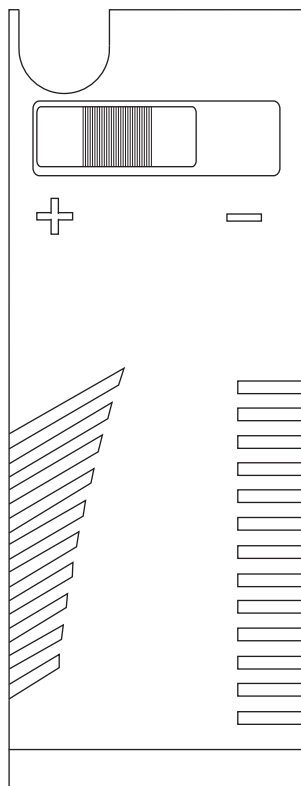
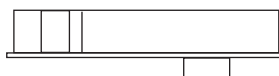
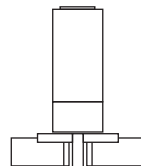
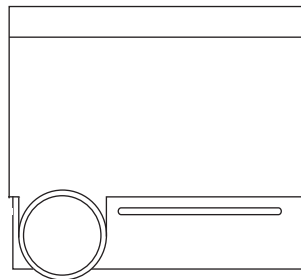

Installation 302-LV

All of the smaller models are low voltage with the transformer located on the plug. They come fully assembled and are ready to use.

1. Decide on which outlet option to use.

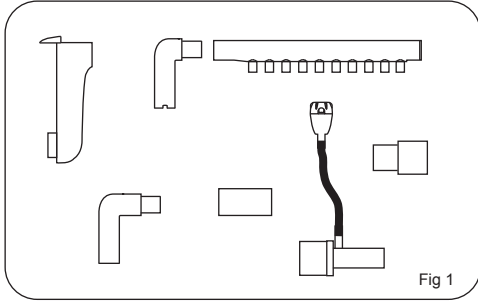

a) If no attachment is required simply push the 13mm or 9mm outlet into the pump outlet.

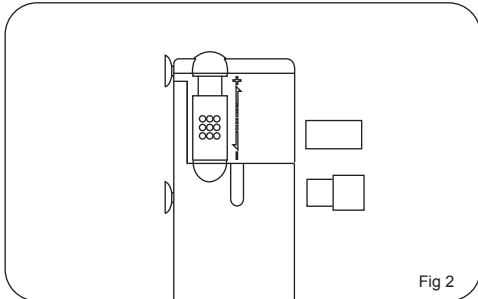

b) If the venturi is required, push venturi outlet directly into pump outlet, hang airline outside of your aquarium.

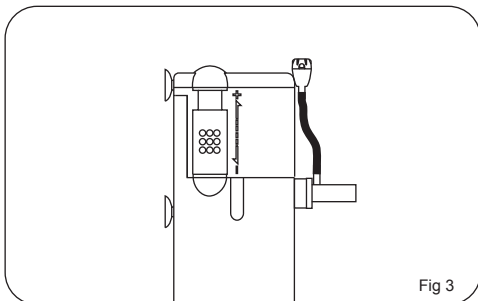

c) If the spray bar is to be used, push upright adaptor directly into pump outlet then connect spray bar with elbow into top.

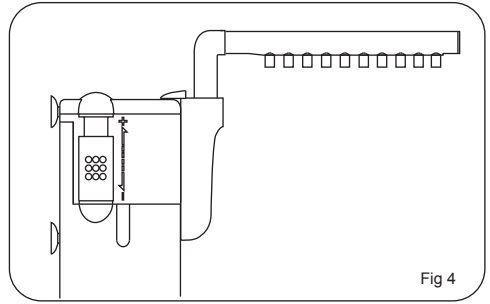

OR use the use the outlet elbow by its self.

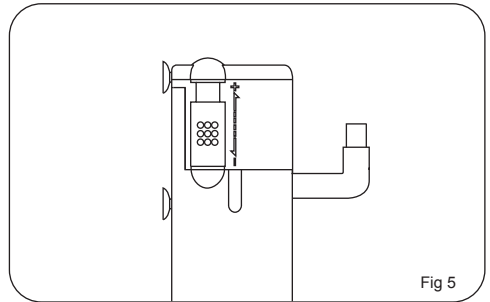

2. Suction cups will fasten the filter to the wall of your aquarium. It is best to have surface agitation if it is being used as the sole filter.

3. Use flow adjuster on the side of the filter:

- + will allow full flow
- will reduce the flow

Remember the more flow the better.

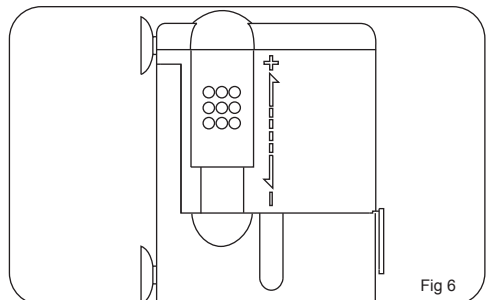

Maintenance 302-LV

1. Unplug from the power supply. Take to sink.
2. Remove the sponge casing from motor to access the filter sponge.
3. Remove sponge and squeeze gently a few times in a bucket of aquarium water. It is important to not wash the sponge too thoroughly and never wash it in tap water.

Accessing The Impeller

Clean the impeller at least once a month.

1. Grasp the motor with one hand and filter casing with the other and gently pull apart.
2. Remove the impeller cover to gain access to the impeller.
3. Pull impeller from the motor and rinse properly. Use an *Aqua One* double ended pipe brush to clean the impeller and the impeller well and also any of the outlet options that are being used.
4. Put the filter back together and return to the aquarium. Ensure your hand is not wet, plug in at the power supply and turn on.

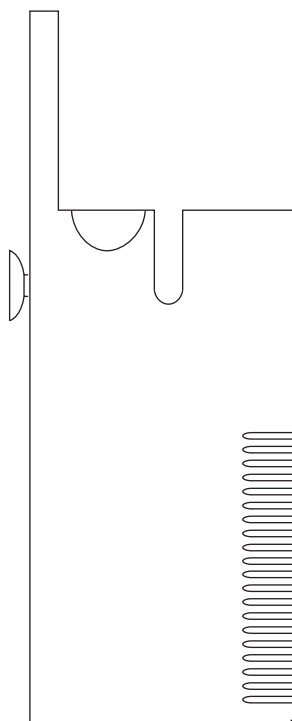
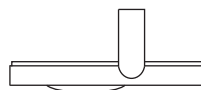
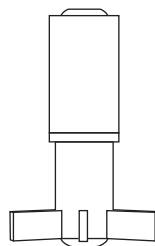
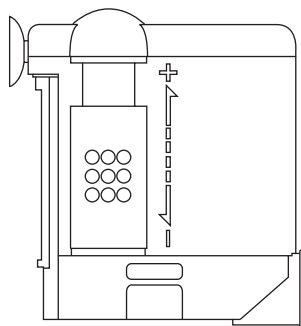

Aqua One - 2 + 1 Year Guarantee

Congratulations on your purchase of a quality Aqua One product. This product will last for many years under normal usage the guarantee commences from the day of purchase. You must provide proof of purchase when you submit your equipment for repair under guarantee.

The benefits given to the purchaser by the manufacturers guarantee are in addition to all other rights and remedies which the purchaser has in respect of the equipment under the legislation of the appropriate country of purchase.

Your 2 year guarantee can be extended by a further 1 year upon registration with the distributor. This can be done online at the address below or by completing the extended guarantee registration card and returning by post to the address of your country of purchase.

www.aquaone.com.au

General Guarantee Conditions:

1. All claims for guarantee service should be made to the place of purchase.
2. You must provide proof of purchase when you submit your equipment for repair under guarantee.
3. This guarantee extends only to defects occurring in materials or workmanship under normal use of the equipment when operated in accordance with the supplied instructions.
4. Replacement equipment is guaranteed for the remainder of the original manufacturer's guarantee period.
5. Guarantee does not cover:
 - a. Cost of freight, postage or the cost of insurance.
 - b. Service costs arising from failure to correctly adjust the controls of the product or to clean the hoses, filter media, impellers, pump heads, failure to observe the manufacturer's instructions or inspections that reveal that the equipment is in normal working order.
 - c. Equipment failures caused by misuse, neglect, normal wear and tear, accidental breakage, repairs or modification by unauthorised persons, lightning strikes, mains voltage fluctuation, earthquakes, vermin infestation or liquid spillage.
 - d. Consumables, such as impellers, shafts, filter cartridges, filter media, sponges or wool.
 - e. In no event will the manufacturer or distributor of that country be liable for any consequential or incidental damage including, but not limited to loss of livestock, property damage, damage to equipment, appliances or furnishings arising from the use of this product or from failure of this product.
 - f. Damaged incurred in transit resulting from inadequate packing.
6. It is recommended that all equipment subject to claim should be prepared for transportation in its original packaging or other suitable packaging which offers the same degree of protection.