

Radiance



Aqua One®

60 / 90 / 120

Inspiring Excellence in Fish Keeping!



Instruction version: 21/07/2010

www.aquaone.com.au

Important Safeguards

To guard against injury, basic safety precautions should be observed, including the following:

1. Read and follow all safety instructions and important notices in these instructions as well as on the product itself.

2. This appliance is not intended for use by children or infirm persons without supervision. Young children should be supervised to ensure that they do not play with the appliance.

3. To avoid possible electric shocks, special care should be taken since water is employed in the use of aquarium equipment. For each of the following situations do not attempt repairs yourself. Return the appliance to an authorised service facility for service or discard the appliance.

a. If the appliance or any electrical component of the appliance (non-immersible equipment only) falls into the water or gets wet, do not reach for it. Unplug it and then retrieve it.

b. If the appliance shows any sign of abnormal water leakage, immediately unplug it from the power source.

c. Carefully examine the appliance after installation. It should not be plugged in if there is water on parts which are not intended to be wet.

d. Do not operate the appliance if it has a damaged cord or plug, or if it is malfunctioning, or dropped or damaged in any manner.

4. A “drip loop” (see graphic) should be arranged for each cable connecting an aquarium to a power supply. The drip loop is the part of the cable below the level of the power supply. It prevents water travelling down the cable and coming into contact with the power supply. If the plug or the socket does get wet, do not unplug the appliance. Disconnect the fuse or circuit breaker that supplies the power to the appliance, then unplug and examine for presence of water in the socket.

5. Always unplug the appliance from the electrical outlet when not in use, before putting on or taking off parts, before any type of maintenance or cleaning.

6. Never yank the cable to pull it from the socket. Pull the plug carefully to disconnect.

7. Do not use the appliance for reasons other than the intended use. The use of attachments that are not recommended or sold by the manufacturer may cause the product to be unsafe. This is not recommended.

8. Do not install or store the appliance where it will be exposed to weather or temperatures below freezing.

9. Make sure any component mounted on a tank is securely installed before operating it.

10. Ensure input voltage is the same voltage as your local power supply.

11. If an extension cable is used it should have the proper rating. Care should be taken to arrange the cord so that it will not be tripped or pulled.

12. A G.F.C.I (Ground fault circuit interrupter) & surge protector is recommended for all electrical appliances.

13. Ensure your hands are dry when turning the power switch on/off and when inserting/removing the power cable from the socket.

14. If you are in any doubt about the electrical installation or safety of this product you must consult a qualified electrician.

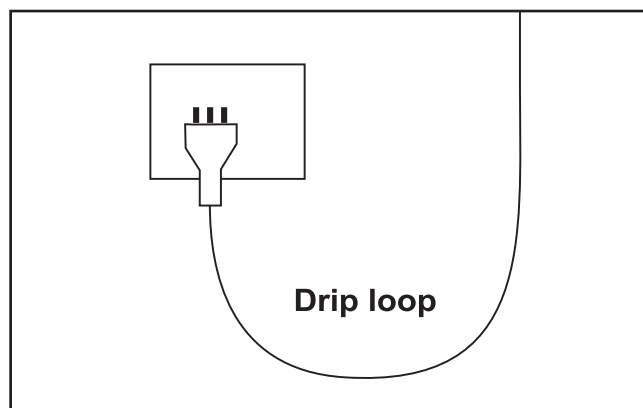

For Guarantee Conditions, please refer to the Guarantee form that is enclosed with this product.

All products are supplied with fitted plugs. This plug should not be tampered with in any way or removed. Removal or tampering with the plug invalidates our guarantee offered with this product.

For UK a 3 pin adaptor is supplied with the product and this must be used.

Before First Use / Preparation

Read and follow all the instructions, even if you feel you are familiar with the product and find a place to keep the instructions handy for future reference. Your attention is drawn particularly to the sections concerning “**IMPORTANT SAFEGUARDS**” and the “**GUARANTEE CONDITIONS**”. Please ensure you retain your original purchase receipt in the event that guarantee service is required.

Carefully unpack the filter making sure you keep all the packing material until all the parts of the product have been found and the product has been assembled.

This product is shipped to you in a factory sealed carton. Should the product malfunction in any way or if the unit is damaged and requires replacement, contact the retailer where the product was purchased for inspection.

Know Your Light

60 / 90 / 120

Set up/Parts

1. Suspension cable anchor points
2. Fans
3. Control Panel
4. Tank Bracket
5. Cable connection

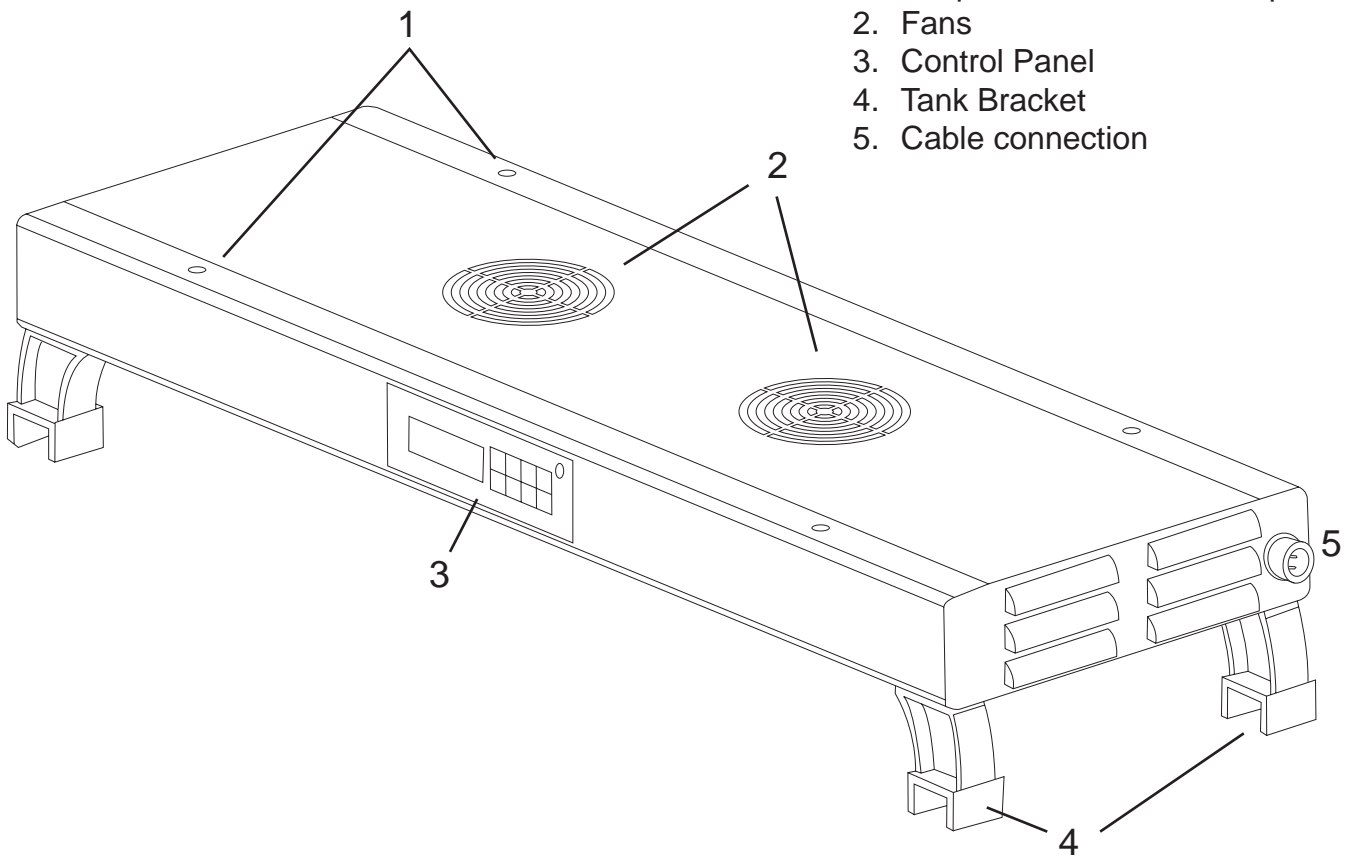

Installation

Tank Mount

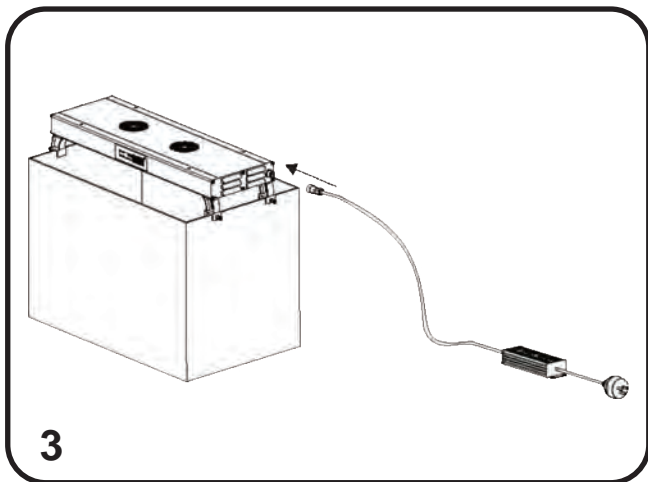
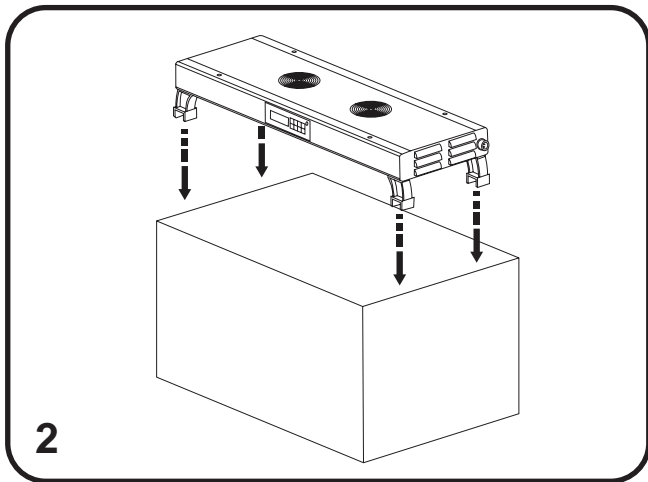
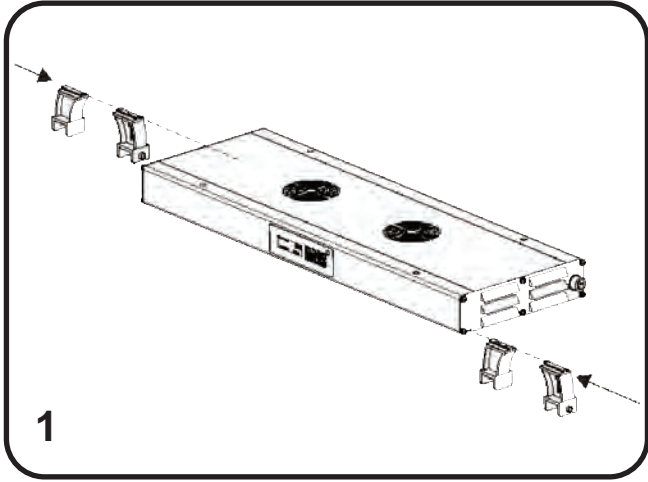

Suspension Mount

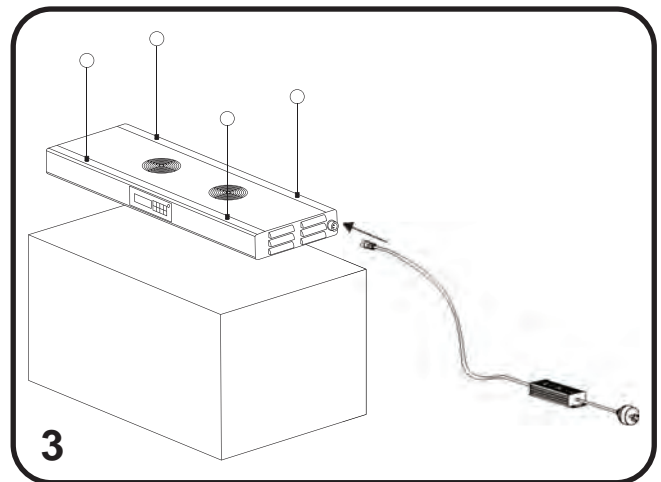
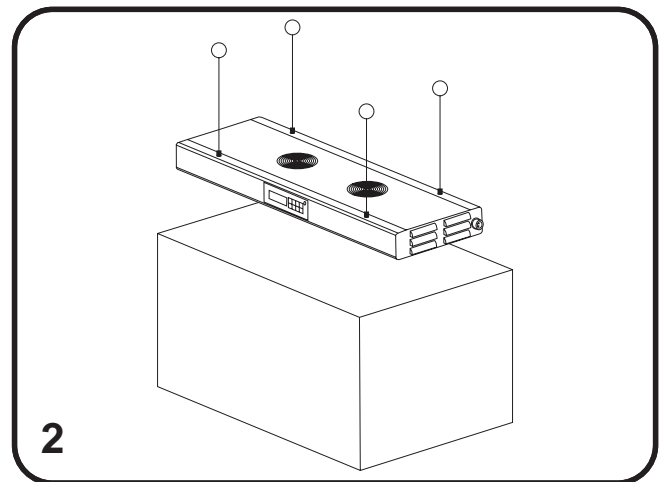
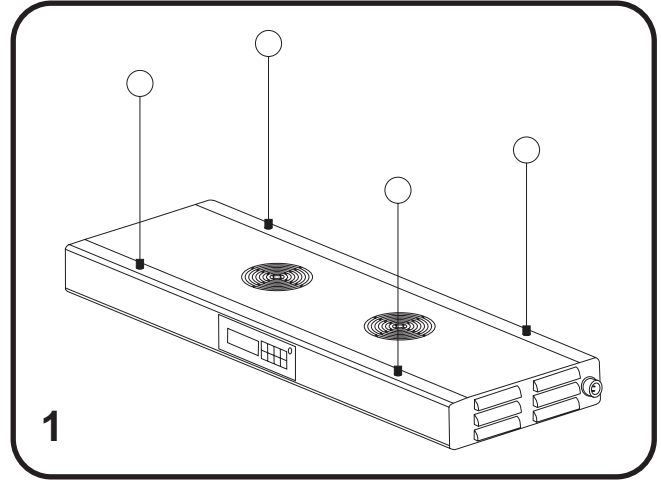

Installation

First, select how you would like to mount the light unit over your aquarium. The light can be placed directly onto the aquarium using the supplied mounting brackets or it can be suspended above the aquarium using the supplied suspension cables. In order to suspend the light unit, you will need to have mounting points which can be either anchors on the ceiling or a bar or frame above the aquarium. Ensure that whatever the light unit is to be suspended from will support the weight of the light unit.

NOTE: The tank brackets can only be used if the length of the aquarium is equal to or less than the length of the light unit.

Tank Mount

1. Slide the brackets into the channels on the underside of the light unit. Ensure that the brackets are facing the right direction, the holes for the fastening screws should face towards the outside. The channels are only accessible from one end of the light unit, the rear channel is on the left hand side and the front channel is on the right hand side.

2. Place the light unit over the aquarium. Slide the brackets along the channel to ensure the bracket is centred over the aquarium. Secure the fastening screws.

3. Connect the power supply to the light unit. Align the pins in the socket with the holes in the plug. Push the plug into the socket (**NOTE:** the plug only fits into the socket one way due to a groove in the top of the plug) and secure it by tightening the threaded cover.

The power supply should be placed in a well ventilated area and should be placed on a hard surface (such as timber or tiles) due to the operating temperature.

NOTE: The 90 & 120 units are supplied with 2 power supplies.

Suspension Mount

1. Attach the Suspension cables to the light unit. There are 4 anchor points in the top of the light unit, there is a male threaded connector on one end of each suspension cable, these screw into the anchor points.

2. Suspend the light unit over the aquarium. To raise the height of the light unit above the aquarium, pull the cable through the connector at the lower end of the cable. To lower the light unit, press the top of the connector where the cable enters. Make sure the light unit is supported when doing this so that the light unit does not fall too quickly.

3. Connect the power supply to the light unit as described above.

Function Keys

Use the Function keys as described below.

PWR

Power button. Switch the unit on/off by pressing the PWR button for 3 seconds. The light unit will power up to the programmed intensity or power down rather than switching immediately on or off, this is to reduce wear on the LEDs and extend the life of the unit.

Press the power button to activate the control panel display. The display switches off after 90 seconds of inactivity.

LUM+ / LUM-

Increase/decrease the light intensity in manual mode. Scroll up/down in menus.

SRC

Switch between white only, blue only and white + blue.

MODE

Switch between auto and manual mode. Manual W allows the white intensity to be adjusted, Manual B allows the blue intensity to be adjusted.

COMP

Switch light compensation on/off. Light compensation mode allows the unit to dim based on ambient light conditions to save power. In a brightly lit room, the unit will dim so that the aquarium still receives the same amount of light. In a poorly lit room, the intensity will increase.

OK

Select option from menu. Save settings and return to menu.

ESC

Exit the menu.

Operating Instructions

The light unit can be operated in one of two ways - Auto or Manual Mode.

Auto mode allows the user to set the light unit to automatically switch on and off as well as increase and decrease intensity between different time points. Auto mode can be used to replicate a natural lighting cycle, including sunrise/sunset, moonlight and cloud cover. Manual mode allows the user to adjust the intensity of the blue and white channels independently to suit specific requirements.

NOTE: Whilst in manual mode, functions such as timer, moonlight and clouds will not function.

Numbered steps on this page refer to the numbers on the settings menu.

AUTO MODE

The light unit comes with factory default settings that allow the light unit to be used without any changes in settings as long as the time and date are set. Changes to any or all settings can be made as follows:

Enter the menu by pressing the MODE button for 3 seconds.

1. Time: Set the time and date.

Using the LUM+/LUM- buttons, set the hour. Press ok to move to the next number. Repeat until the time and date are set.

Time points

The default time points are as follows:

Time Point	Time	Intensity
1	06:00	0%
2	08:00	60%
3	12:00	100%
4	14:00	100%
5	17:00	50%
6	19:00	0%

2. Point 1: The time point will display a time and a percentage, this is the light intensity at that time. Select the time by hour, press OK, select the minutes, press OK, select the intensity and press OK again.

3-7. Points 2-6: Adjust the remaining time points as above.

The following diagram shows the light intensity profile over 24 hours and shows how the light shifts between time points.

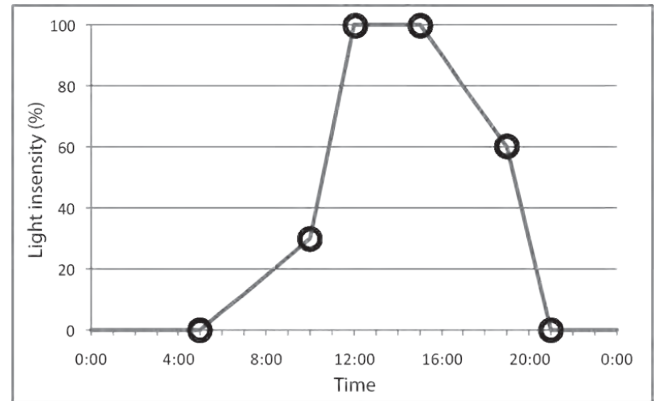

An example of how light intensity changes between time points.

8. Light compensate: In light compensation mode, the degree of compensation can be adjusted. The value can be adjusted from 1-10. Higher values will increase the amount the intensity rises or falls relative to the ambient light.

Default Value = 5

9. Cloudy: Adjust the amount of cloudy days. 0 = low number of cloudy days, 5 = regular cloudy days.

Default value = 0

10. Moonlight: Adjust the maximum intensity of moonlight. (0-30%)

Default value = 15%

To remove the moonlight feature, set the moonlight value to 0.

11. B-W Select: Set the relative ratio for colour in auto mode.

0 = blue and white at equal intensity (default value)

1 = blue 100%, white at selected ratio

2 = white 100%, blue at selected ratio

12. B-W Ratio: Select the ratio when B-W select has a value of 1 or 2.

Selecting a value of 90 will make the white:blue ratio 90:100 when B-W Select value is 1 and vice versa when the value is 2.

Default value = 100

13. Back to Default: Reset all values to default.

MANUAL MODE

1. To set the time and date refer to AUTO MODE instructions.

Press MODE to bring up Manual W on the display. Use the LUM+ and LUM- buttons to select the desired white intensity. Press MODE again to bring up Manual B on the display. Use the LUM+ and LUM- buttons to select the desired blue intensity. Leave the display in Manual mode (displaying either Manual W or Manual B).

Aqua One - Guarantee 1 + 1 Year

The additional 1 Year **Extended Guarantee** applies when you REGISTER online with Aqua One. Register your Extended Guarantee at www.aquaone.com.au

About this Guarantee

The Manufacturer or Distributor, of Aqua One goods, is collectively known herein as "Aqua One". Please refer to contact details for Aqua One below or on the applicable Aqua One website. Any product that is covered by its own Guarantee (as enclosed with the product) is subject to the conditions of that Guarantee.

The benefits given to the purchaser, under Guarantee, are in addition to all other statutory rights and remedies which the purchaser has in respect of goods under legislation in the applicable country of purchase. This Guarantee shall not affect any such rights and should be read subject to such legislation.

1.0. Terms and Conditions of Guarantee.

- 1.1. Aqua One warrants to the purchaser, for 1 Year from date of original purchase, to repair or replace goods where fault is found due to defective materials or faulty workmanship and where goods do not operate in accordance with the instructions.
- 1.2. All claims for repair or replacement must be made at place of purchase.
- 1.3. The original and dated Proof of Purchase (receipt) must be supplied with all goods claims. Please also provide this Guarantee where possible.
- 1.4. The Guarantee covers the Aquarium against gluing breakdown resulting in leakage.
- 1.5. All goods subject to claim under Guarantee should be prepared for transportation in the original packaging or other comparable packaging which offers the same degree of protection.
- 1.6. Where goods are repaired or replaced under Guarantee, these goods are Guaranteed for the remainder of either the original Guarantee or Extended Guarantee period.
- 1.7. Where claims on inspection reveal goods are in normal working order, Aqua One will request reimbursement of all reasonable costs incurred.

2.0. Other Terms and Conditions – Extended Guarantee

- 2.1. The Extended Guarantee period is for an additional 1 Year and commences on expiration of the standard guarantee period.
- 2.2. Application for Extended Guarantee is FREE of any registration cost to the purchaser on completion of the Extended Guarantee questionnaire which is found on the applicable Aqua One website (refer below).
- 2.3. Upon receipt and acceptance of the questionnaire, Aqua One will forward (by way of email) a Certificate of Extended Guarantee to the purchaser.
- 2.4. For more information on how we collect, hold, use and disclose personal information provided to us, please refer to our Privacy Statement on the Aqua One websites or write to our Privacy Officer, in your country of purchase.
- 2.5. Where Aqua One determines goods are being used in a manner contrary to the instructions, specifications or this Guarantee, Aqua One reserves the right to terminate Extended Guarantee for such goods and will provide written notice to the purchaser.

3.0. Exclusions and Limitations

Where permitted by local law, the following exclusions and limitations apply in regard to Guarantee:

- 3.1. Goods claims where fault is due to, but not limited by a) misuse b) neglect c) abuse d) fire or flood e) normal wear and tear f) accidental breakage g) Acts of God h) mains voltage fluctuation or supply problems i) connection to any voltage other than what is stated on the rating plate j) modification or tampering to electrical cord or plug, k) vermin, insects or foreign object l) liquid spillage or submersion of goods not designed to sustain such use or duress.
 - 3.2. Where inspections reveal goods are in normal working order including where noise or vibration is consistent with normal goods operation.
 - 3.3. Attempted repairs or modifications by unauthorised persons, including but not limited to the drilling of holes in the aquarium glass by unauthorised persons.
 - 3.4. Where the goods factory rating plate has been removed, altered, damaged or is rendered illegible.
 - 3.5. Where goods are not installed, operated or maintained in accordance with Aqua One's goods instructions, specifications or this Guarantee.
 - 3.6. Replacement or repair of worn consumables or replacement of lost goods, parts or components.
 - 3.7. Costs associated with goods transportation, removal, installation, postage or cost of insurance.
 - 3.8. Any damage incurred whilst installing, transporting or moving the goods.
 - 3.9. Subject to certain local statutory rights and obligations to the contrary, and this guarantee shall not affect those rights or obligations, where, to the full extent permitted by law: 1. all express and implied warranties and conditions under statute or general law, are expressly excluded and Aqua One, where permitted, will limit liability as follows and at Aqua One's option to: in regard to goods either a) the replacement of goods or supply of equivalent goods b) the repair of goods or the cost of replacing the goods or of acquiring equivalent goods OR in regard to services either c) the re-supply of services d) the cost to re-supply services.
2. Aqua One will not be liable for any loss or damage, including consequential loss or damage either directly or indirectly, or for any incidental expenses, of any kind, and in any way whatsoever.

The additional 1 Year Extended Guarantee applies when you REGISTER online with Aqua One. Register your Extended Guarantee at www.aquaone.com.au

(1) Consumables include items such as replacement light tubes.

Aqua One may be contacted in: Australia Kong's (Aust.) Pty. Limited PO Box 863, Ingleburn 1890 NSW Australia www.aquaone.com.au
--



www.aquaone.com.au

® Aqua One is a registered trademark.